

WOODFIELD

Safe Hands

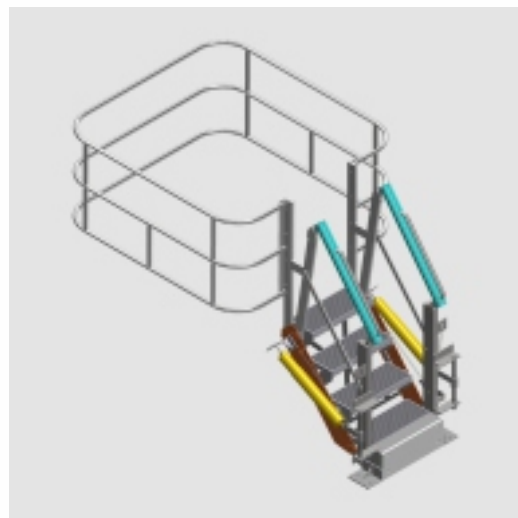
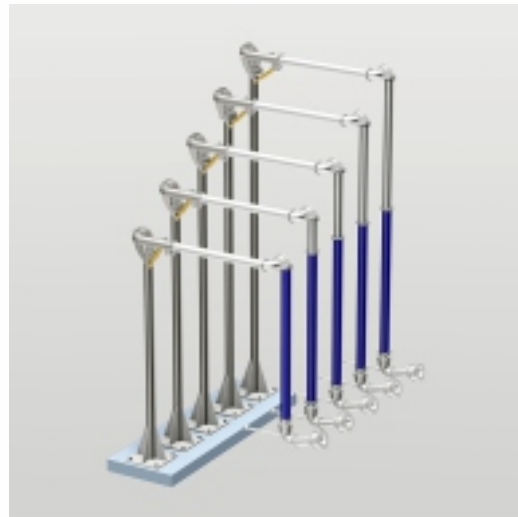

ABOUT WOODFIELD

Woodfield Systems International is a premier design, manufacturing, sales & service organization providing customized bulk fluid handling and safety access solutions for loading and unloading product in the oil & gas, chemical, petrochemical and aviation sector.

Woodfield Systems International manufactures loading arms and safety access systems, and provides metering and pumping packages integrated into a complete solution to meet the needs of our clients.

Designed and manufactured by an experienced team of dedicated engineers, and backed by an experienced international sales force, Woodfield Systems International has created a strong base of loyal customers in the oil, gas and chemical transportation sector in the Middle East, Far East, Indian Sub-continent and the CIS.

As our products, services and capabilities expand, so does our international reach. We continue to expand our sales and support channels into other international markets through partnering with strong ambitious companies that share our passion for achieving excellence through honesty, integrity and devotion to providing the best total solution for our clients.

With an inherent culture for product and service development backed by an **ISO 9001:2008, ISO 14001:2004, BS OHSAS 18001:2007 & PED: CE** Integrated quality management system and a passionate leadership team, Woodfield Systems International will continue to keep all our clients and team members **"in safe hands"**

www.woodfieldsystems.com

WOODFIELD PRODUCTS AND SERVICES

Top and Bottom Loading Arms

- Truck, Rail car and barge loading and unloading
- Industry sectors: Oil & Gas, Chemical, Industrial, Aviation.
- Balancing options: Counterweight, compression spring, gas strut, hydraulic or pneumatic
- Materials: Carbon steel, aluminum, stainless steel, specialty alloys (monel, inconel, hastelloy, duplex and super duplex stainless-steel, 904l), PTFE lined construction
- State of the art swivel joint technologies & designs to suit each application
- Accessories include ground monitoring, high level detection, Local Control Panels, vapor recovery, hoses, couplers, dry disconnects, breakaways, emergency shut-down, steam jacketing, electrical heat tracing and insulation

Swivel Joints:

- Single race, dual race, triple race
- Single split flange, dual split flange
- Hardened raceways
- Carbon steel, aluminum, stainless steel, special alloys as above
- All "Styles"



Safe Access Systems:

- Folding stairs and gangways in aluminum, carbon steel, stainless steel and fibre glass
- Safety cages in aluminum and stainless steel
- Spring balanced, pneumatic or hydraulic operation
- Tracking gangway systems: manual or powered

Floating Suctions:

- Fixed reach or “scissor” style for above- or below-ground storage tanks
- 2” to 12” in aluminum, stainless steel or special alloy

Metering and Pump Skid Packages:

- Coriolis, PD and turbine meters
- Custody transfer systems
- Batch controller/Preset or flow computer controlled
- LPG, NH3 with vapor recovery
- Meter prover connections
- System integration
- Electric, hydraulic or engine driven pump units
- Centrifugal, PD, progressive cavity pumps
- FAT, SAT

Capabilities include:

- Onsite service, commissioning and training
- FAT, SAT
- Certified by TUV Nord as ISO 9001:2008, ISO 14001:2004, OHSAS 18001:2007 & PED: CE 97/23/EC
- Certified TIG and MIG welding
- Robotic welding
- CNC profile cutting
- In-house hydro test, X-ray, dye penetrate, shot blast and painting
- In-house CNC machining
- In-house swivel joint testing
- 3D modeling for design and detailing
- Finite Element Analysis (FEA)
- Computational Fluid Dynamics (CFD)



Woodfield Systems International Pvt. Ltd.

302-A, Nitco Biz Park, Plot No. C-19, Road No.16,
Wagle Estate, Thane (W) - 400604.
Phone: +91-22-6704 0000 | Fax: +91-22-6704 0099
Email: sales@woodfieldsystems.com
www.woodfieldsystems.com

WOODFIELD

Safe Hands



The Contents of this publication are presented for information purpose only, and while effort has been made to ensure their accuracy, they are not to be construed as warranties or guarantees, expressed or implied, regarding the products or services described herein or their use or applicability. All sales are governed by our terms and conditions, which are available on request. We reserve the right to modify or improve the designs or specifications of our products at anytime without notice and hence are subject to change. Woodfield Systems International Pvt. Ltd. accepts no responsibility for any errors that may appear in this description. This catalogue is a property of Woodfield Systems International Pvt. Ltd. Any Reproduction or Reprint or Replication of this content is prohibited.