

the next generation
PINCH VALVES

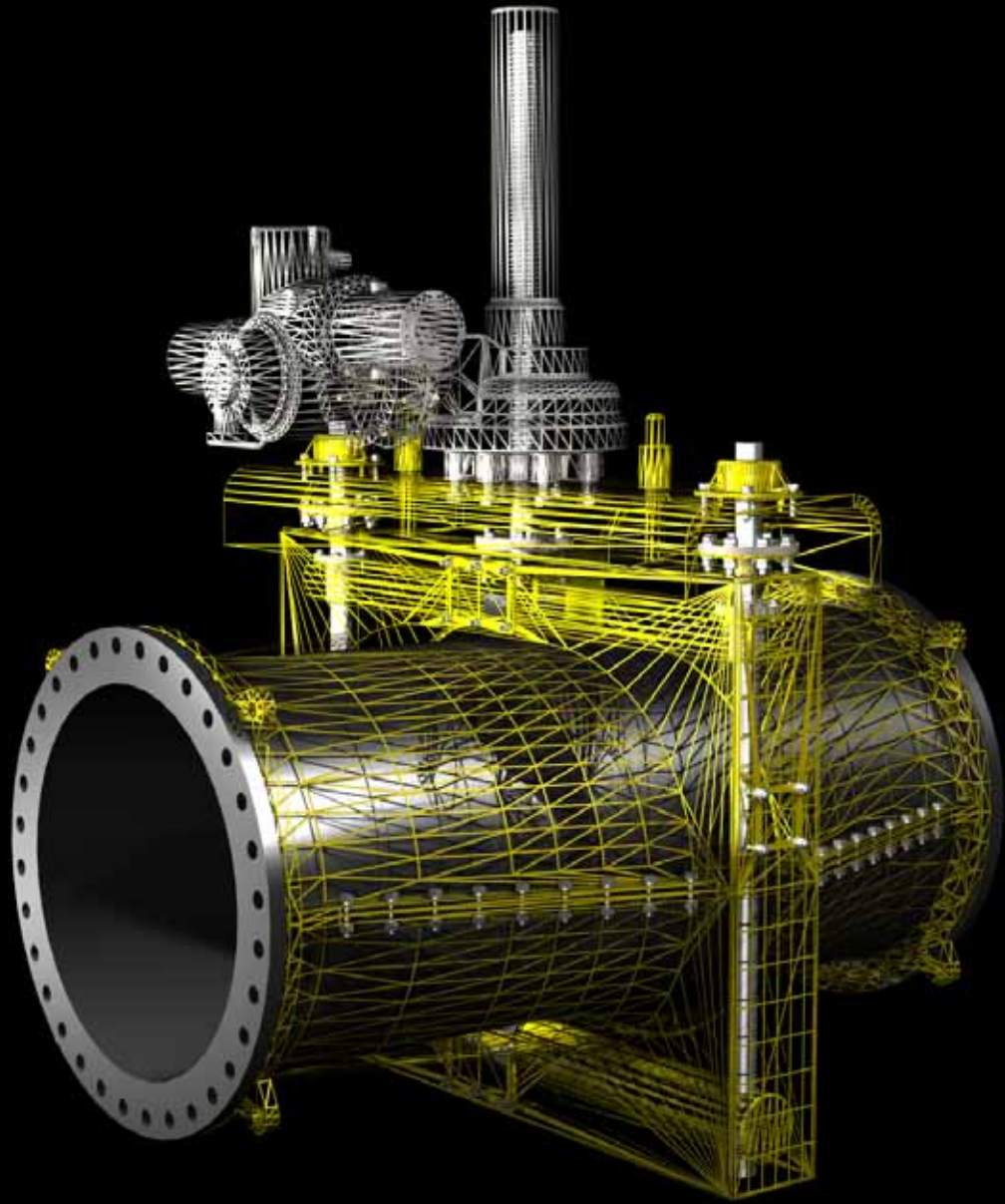

PINCH VALVES THE NEXT GENERATION V5



Jindex, Global Leader in VALVE DESIGN

Contents

P3	Why use a Pinch Valve?
P5	Jindex Innovation 1 - Fast Sleeve Change
P6	Jindex Innovation 2 - Sleeve Technology
P8	Engineered Valves
P8	Failsafe Systems
P9	Research and Development
P10	Jindex Spare Sleeve Model Codes
P11	Jindex Pinch Valve Model Codes
P12	Jindex Pinch Valve Dimensions
P14	Flow Rate Calculations
P15	Typical Industries and Applications / References
P16	Jindex Product Overview

Why use a pinch valve?



Various Enclosed Pneumatic Pinch Valves with limit switches

The Jindex Pinch Valve range has been designed to solve process problems associated with controlling the flow of abrasive or corrosive fluids. Industries such as mineral processing, pulp and paper, power generation, chemical handling, effluent treatment, water and waste water use the Jindex Pinch Valve.

The Jindex Pinch Valve consists of a tough but flexible, full or reduced bore cylindrical sleeve which forms part of the pipeline. The valve is closed mechanically via movement of the pinch bars located on opposite sides of the sleeve.

Simple designs are often the best. Most other valve types use multiple components such as glands, packing, seats, seat retainers, inner linings and outer casing, wear surface, and main control components such as discs, shafts, plugs, gates etc.

The heart of the Jindex Pinch Valve is the sleeve, a single component which performs all of the functions listed above.

The Jindex Pinch Valve will improve system control and lower maintenance costs.

No scale or seat build-up

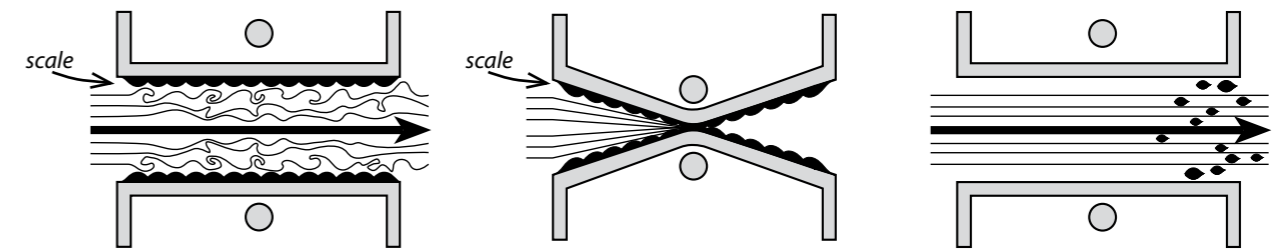

Shut-off achieved even with solids present

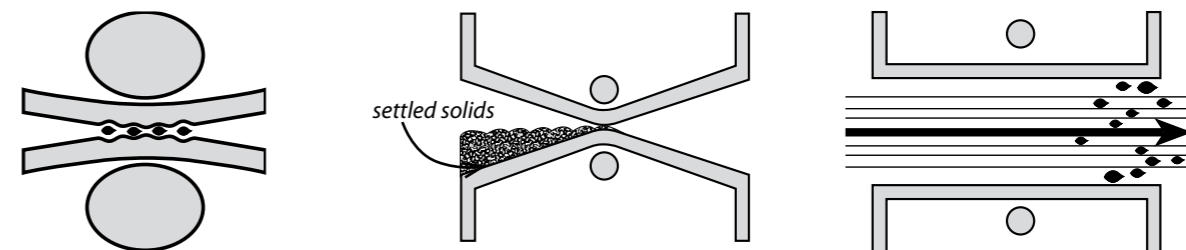

Full-bore open position achieved even with settled solids in pipeline unlike a butterfly valve which often cannot open or close with settled solids in pipeline

Low operating costs



Gold mine circuit

FAST SLEEVE CHANGE

- No need to remove valve from the pipeline or to disconnect electricals or pneumatics

LOWEST PRESSURE DROP OF ANY CONTROL VALVE

- Improved flow

LONG LASTING ABRASION RESISTANT SLEEVE MATERIALS

- Less maintenance down time

SMOOTH FULL-BORE UNOBSTRUCTED FLOW

- Minimises wear

UNOBSTRUCTED FLOW

- Reduces pumping costs

NO GLANDS OR SEATS WHICH REQUIRE REGULAR ADJUSTMENT OR REPLACEMENT

- Increased plant availability time

SINGLE WEARING PART

- Reduces spare parts inventory

Change the Process keep the valve

Jindex can optimise the control characteristics of our valves to suit the application.

As with other control valves in control applications, the Jindex pinch valve works at its optimum with a reduced bore design.

The beauty of the Jindex design is that if process conditions change, a simple change to the sleeve configuration will allow the bore size and control to be easily modified to handle the new flow. All other valve components are re-used.



Tank level control valve - smooth flow deflection

Flow vs. Valve position for
300 mm Jindex Pinch Valve
Density = 1.2 kg/m³, 0.5 m head

Standard Pinch Valve ◆
Control Pinch Valve ▲

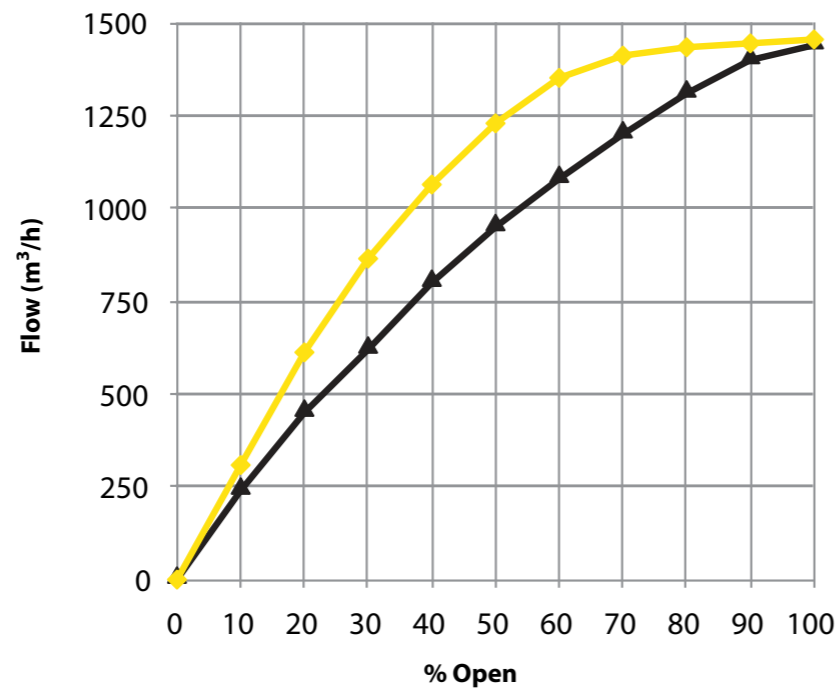

Jindex Innovation 1 Patented FAST sleeve change

FAST CHANGE = SHORT DOWNTIME = LOW COST = UNDER BUDGET

The unique FAST sleeve change allows the sleeve to be changed without having to remove the valve from the pipeline or disconnect electricals and pneumatics.

Example:
Maintenance equipment and personnel
for a 150 mm (6 inch) sleeve replacement

Item	Traditional Pinch Valve	Jindex Pinch Valve
Personnel	1 electrician, 2 fitters	1 fitter
Equipment	Crane, Forklift etc.	None
Heaviest lift	100 lb (45 kg)	11 lb (5 kg)
Downtime	1 hour	10 minutes

Traditional Pinch Valve

With traditional Pinch Valves, changeover of worn sleeves can be a long and complicated process. Due to the mechanism of sleeve retention, traditional pinch valves require removal of the valve from the pipe and partial or complete dismantling to replace the sleeve. This removal necessitates disconnection of power, control and pneumatic cabling.

For traditional pinch valves above 150 mm (6 inch) their weight requires hoisting equipment resulting in extra delays.

Jindex Pinch Valve

The patented FAST sleeve change system reduces changeover time from hours to a matter of minutes with no requirement for extra personnel or lifting equipment. This translates directly to the bottom line by increasing plant availability.



Single Ended Pinch Valve, Pneumatic Actuator with Manual Override

5 easy steps



1 Remove tie rod pins and lower pinch bar



2 Remove flange bolts and backing flanges



3 Remove worn sleeve and replace with new sleeve



4 Replace backing flanges and flange bolts



5 Replace lower pinch bar and tie rod pins

Jindex Innovation 2 Sleeve Technology

Full Bore/Reduced Bore

- Allows optimised flow control
- Optimises wear life
- Eliminates the need for a totally new valve for future flow increase
- Jindex has a wide range of sleeve moulds for each valve size
- Available in most sleeve materials

Variable Wall Thickness

- Jindex has different wall thickness moulds for each bore size to optimise wear life

Rubber

- Natural, Butyl, Hypalon, Neoprene, Nitrile, and EPDM and others available
- State-of-the-art reinforcing allows for thicker wear layers when compared with other pinch valve sleeves
- Opening tags are available which attach the sleeve to the pinch bars. These are used in gravity or low pressure applications when the valve is shut for extended periods

Polyurethane

- Polyurethane sleeves allow greater scope for optimising wear life
- Jindex has done extensive on-site development work with polyurethane sleeves to overcome the known 'trouble spots' with rubber sleeves, such as large particle control

ReoThane Extreme Duty LASTS UP TO 4 TIMES LONGER

- ReoThane is the premium reinforced rubber/polyurethane composite sleeve supplied by Jindex
- ReoThane combines superior wear resistance of polyurethane with the resilient flexibility and structural reinforcement of natural rubber
- ReoThane allows higher pressure ratings than polyurethane sleeves
- ReoThane is used for 'extreme' wear and corrosion applications
- Various ReoThane formulations can be designed to match process conditions

Food Grade Materials

- Jindex ALSO has sleeves available in food grades
- White rubber available



4 x 400 mm Double Ended Water Treatment Control Valves with Neoprene Sleeves

Sleeve Material Guide

1 = Not Recommended 2 = Fair 3 = Good 4 = Very Good 5 = Excellent

Property	Natural Rubber	Butyl Rubber	Nitrile Rubber	Neoprene	EPDM	Polyurethane	ReoThane	Hypalon	
Abrasion Resistance	4-5	2-3	2-3	3	2-3	4-5	5	3-4	
Temperature Range	°C	-55 to 80	-50 to 125	-40 to 120	-40 to 80	-50 to 120	-30 to 60	-30 to 60	-40 to 125
	°F	-67 to 176	-58 to 257	-40 to 248	-40 to 176	-58 to 248	-22 to 140	-22 to 140	-40 to 257

Chemical Resistance	Natural Rubber	Butyl Rubber	Nitrile Rubber	Neoprene	EPDM	Polyurethane	ReoThane	Hypalon
Acids	2-3	4	3	3	3-4	4	4	4
Alkali	2-3	4	2-3	2-3	3-4	4	4	4
Aromatic Oils	1	1	3	2	1	-2	2	1
Aliphatic Oils	1	1	4	2-3	1	3	3	2-3
Solvents	1	3	1	1-2	3-4	1	1	1-2
Water	5	3-4	5	3	5	5	5	3-4
UV Stability	1-2	1-2	1-3	4	5	4	4	5

NOTE: Other special materials are available such as high temperature or specific chemical resistance

Vacuum Applications

- Special sleeve design for use in applications where there is a potential vacuum on the down-stream side of the valve
- Eliminates pipeline hammering
- Eliminates variable flow control

Sleeve Wear Detector

- The Jindex Sleeve Wear Detector allows the user to plan routine sleeve changes instead of waiting for a leak to be observed
- When the system is triggered the sleeve will have worn to the point where there is around 10-20% life left before a sleeve change is required
- It can be fitted to all Jindex sleeves



Vacuum Sleeve

Sleeve Wear Detector

“The heart of our design”

Engineered Valves

Specific designs include:

- Solar powered hydraulic systems
- Scaling pipelines that require 'Pigging'
- Highly Corrosive Slurries and Environments
- Special sleeve compounds
- Specialist Alloy body materials
- Unique Lime Dosing Design
- Fly Ash Design
- Pneumatic Conveying Special Design to Reduce sleeve wear
- Pipeline Vibration Dampeners and Control Valves
- Food Grade
- Intelligent Positioner and Accessory Design
 - Foundation Fieldbus
 - Device Net
 - Profibus
 - HART
 - Analogue 4 – 20 mA
- Certification for global and local use around the world

"High Pressure Valves up to 100 bar"



2 x 300 mm, 35 bar Iron Ore Tailings, Hydraulic Actuation



6 x 200 mm, 100bar ash lines, Electric Actuation

In addition to Jindex's standard range of valves which are highlighted in this document, but we also have the capability to design and manufacture to customer specifications.

Our extensive history has been widely involved with plant process and equipment design allowing us

to offer specialised valving designs and advice when required.

Any new design is tested before being sent out to site. This is done at our manufacturing facilities in Australia.

Research and Development

Jindex Research and Development Engineers work across all elements in Valve technology to discover smarter more effective Flow Control solutions. From conception to finished product our Engineering Design team continually utilises our combined state-of-the-art, assembly and test facilities to create and test new designs, all conveniently located within the new Head Office building in Sydney.

Working with state of the art computer modelling we are able to test and analyse all designs to ensure they meet the specified criteria before production commences.

Jindex offers full functional testing over and above our standard Quality Assurance procedures.

Typical testing includes sleeve pressure tests, cyclic performance tests and leak tests.

Contact Jindex with your most difficult applications.



Pressure testing sleeves under controlled conditions

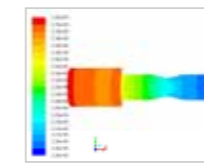

Pressure Drop Analysis

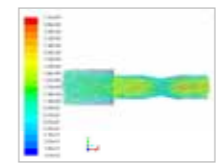

Velocity Analysis

Example Application with Jindex Pinch valves

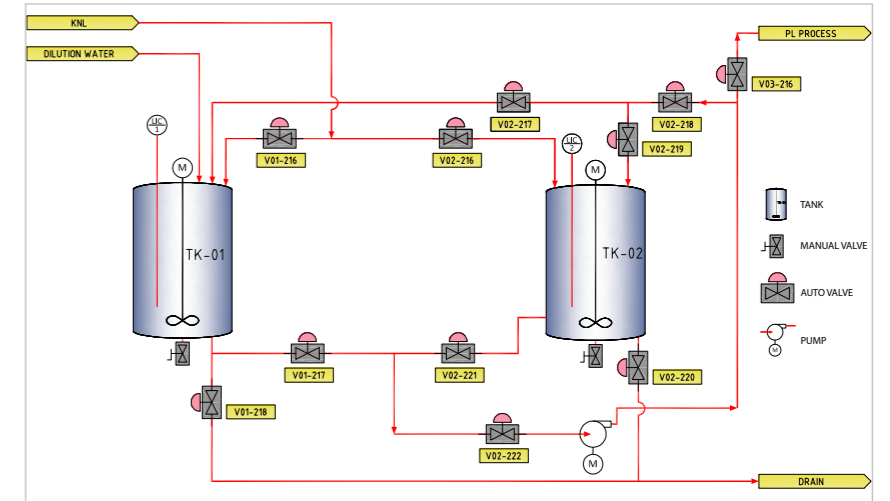

Failsafe Systems



Customised failsafe systems

- Failsafe systems allow valves to open, close, or remain in last position on loss of air or power signal
- We have our own pneumatic piping schematic software to aid design
- As a separate system for client mounting
- Directly mounted on the valve
- We can supply complete systems including air receiver, all controls and weather proof control panels

Single Action Spring Actuators

- Both Spring-to-Open (STO) and Spring-To-Close (STC) actuators are available

"Jindex custom design and manufacture Pinch Valve Systems to suit specific applications"

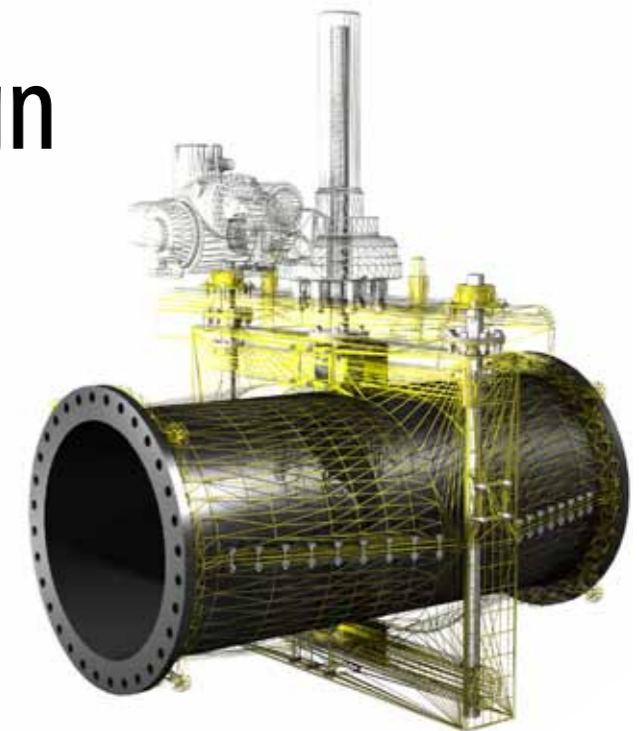

“Jindex can manufacture any style of pinch valve sleeve to suit any type of pinch valve”



Jindex Spare Sleeve Model Codes

Example codes for the same sleeve:

Metric: M 100/80 B2AN—HT
 US: I 4/3B 30AN—HT
 ‘M’ = Metric or ‘I’ = US

- Flange size = 100 mm or 4 inch
- Sleeve bore size = 80 mm or 3 inch
- Sleeve material = Butyl sleeve
- Line pressure = 2 bar or 30 psi
- Flanging = ANSI 150
- Options = High temperature

Most standard spare sleeves are available off-the-shelf.

Emergency spare sleeves can be made in 1.5 days and our factory is within ten minutes of an international airport for quick transport.

Valve Body Size	Valve size (mm)	M [25 – 1200]
	Valve size (inch)	I [1” – 48”]
Sleeve Bore Size	Bore size (mm)	[25 – 1200]
	Bore size (inch)	[1” – 48”]
Sleeve Material	Polyurethane	P
	Natural Rubber	R
	Nitrile	N
	Fly ash Blend	RFA
	Neoprene	NEO
	ReoThane Sleeve	REO
	Butyl	B
	EPDM	E
	Hypalon	H
Line Pressure	Max Working (Bar)	[1 – 100]
	Max Working (psi)	[1 – 1450]
Flanging	ANSI 150	AN
	BS Table D	TD
	BS Table E	TE
	DIN 10	DN
	Other (specify)	XX
Options	Non Standard Length	Specify
	Opening Tags	OT
	High temperature	HT
	Cone Sleeve	CN
	Lime Design	LM
	Wear Detector	WD
	Thick Wall	TW

Actuator Types



Double Acting Pneumatic (PDA)



Single Acting Pneumatic with Spring (PSTC)



Hand wheel and Gearbox (M)



Electromechanical (E)



Hydraulic (H)

Body Types



Non-Rising



Enclosed (E)



Single Ended (S)



Double Ended (D)



Control Valve (SCV)

Jindex Pinch Valve Model Codes

Example codes for the same valve:

Metric: M 150DMB2PDA3LAN-OT
 US: I 6DMB30PDA3LAN-OT
 ‘M’ = Metric or ‘I’ = US

- Size = 150 mm or 6 inch
- Body = Double Ended
- Material = Mild Steel
- Sleeve = Butyl
- Pressure = 2 bar or 30 psi
- Actuator = Pneumatic
- Control = Positioner
- Failsafe = Fail last
- Flanging = ANSI 150
- Options = Opening Tags

Category	Description	Code	Actuator	Description	Code	
Size	Valve size (mm)	M[25 – 1200]	Handwheel/gearbox	M		
	Valve size (inch)	I[1” – 48”]		Dbl. Act. Pneumatic	PDA	
Body	Single ended	S	Sgl. Act. Pneumatic	PSTC		
	Double ended	D	Hydraulic	H		
	Enclosed	E	Electric	E		
Material	Mild steel	M	Control	None	1	
	Stainless steel	S		Solenoid	2	
	Aluminium	A		Positioner	3	
	Ductile Iron	I		Mechanical Switches	4	
				Proximity Switches	5	
	Sleeve	Polyurethane	P	Failsafe	None required	X
		ReoThane	REO		Fail last position	L
		Neoprene	NEO		Fail closed	C
Natural Rubber		R	Fail open	N		
Fly Ash		RFA	Flanging	ANSI 150	AN	
Nitrile		N		BS Table D	TD	
Butyl	B	BS Table E		TE		
Pressure	EPDM	E	DIN 10/SABS	DN		
	Hypalon	H	Options	Opening Tags	OT	
				Wear Detector	WD	
	Max. Working (Bar)	[1–100]		Lime Valve	LM	
Max. Working (psi)	[1–1450]	Non-rising		NR		
			Thick Wall	TW		
			Cone Sleeve	CN		
			Non Standard Length	Specify		

Index Pinch Valve Dimensions Enclosed Body

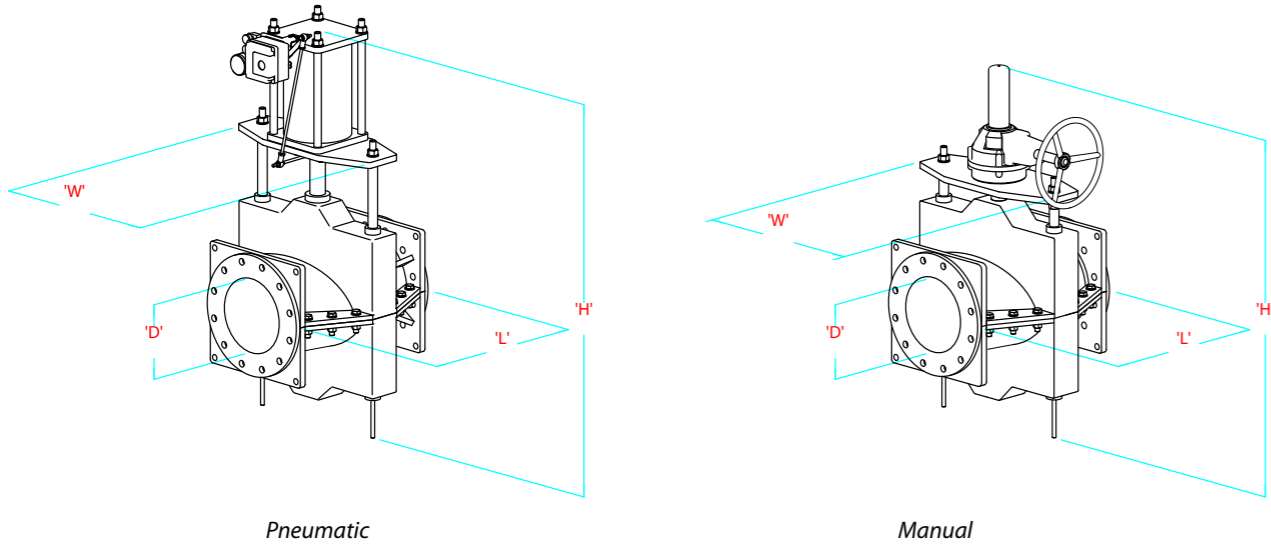

Pneumatic

Manual

Valve Size (D)		Lengths* (L)	Height** (H)		Width (W)	Clearance (C)	Weight (kg)
(mm)	(inch)		All	Pneumatic Manual			
25	1	110	430	410	160	115	14
40	1.5	164	460	430	180	140	18
50	2	164	480	440	180	160	21
65	2.5	164	580	540	215	185	24
80	3	190	630	580	255	200	27
100	4	238	685	620	303	230	30
125	5	300	800	710	407	260	45
150	6	356	940	840	407	290	60
200	8	488	1200	1060	480	350	110
250	10	614	1500	1320	560	410	170
300	12	730	2100	1500	640	490	300
350	14	857	2200	1600	730	540	450
400	16	970	2400	1700	820	600	680
450	18	1090	2550	2200	880	650	900
500	20	1230	2700	2400	950	710	1200
600	24	1465	2900	2500	1075	840	1500
700	28	1715	3100	2600	1200	920	1800
750	30	1845	3300	2800	1250	1010	2100
900	36	2220	3500	2900	1550	1200	2600
1000	40	2455	3700	3000	1770	1280	3000

*Other lengths are available to different standards
**These heights also apply to Non-Rising and SCV

NOTE: All these dimensions are indicative only. Please confirm at time of order.

Index Pinch Valve Dimensions Single Ended Body

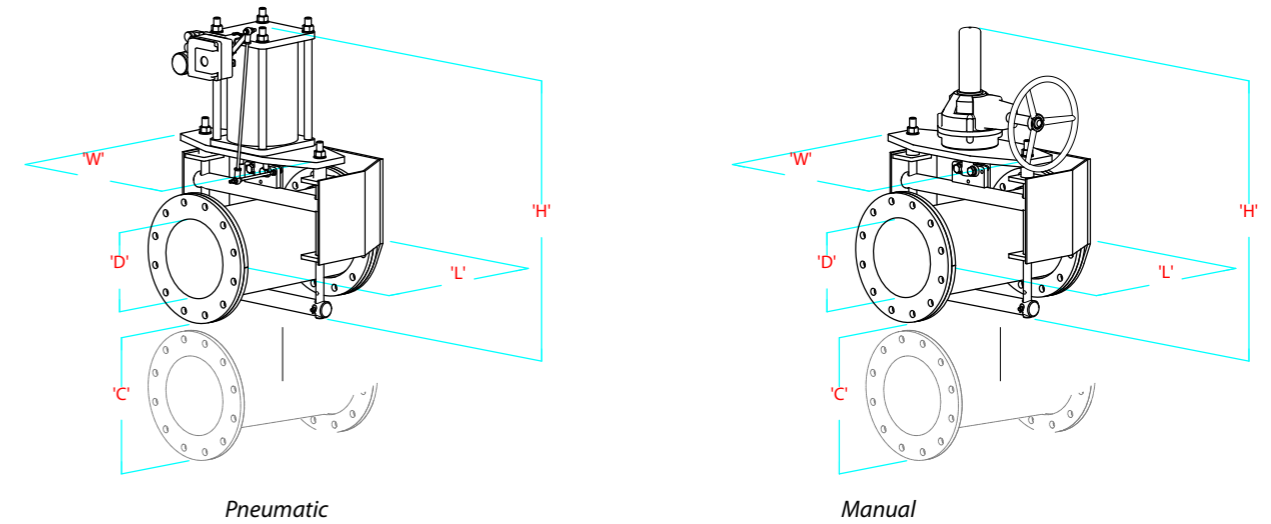

Pneumatic

Manual

Valve Size (D)		Lengths* (L)	Height** (H)		Width (W)	Clearance (C)	Weight (kg)
(mm)	(inch)		All	Pneumatic Manual			
25	1	116	430	320	160	115	9
40	1 1/2	170	460	344	180	140	12
50	2	170	480	355	180	160	14
65	2 1/2	170	580	439	215	185	16
80	3	200	630	476	255	200	18
100	4	244	685	546	305	230	20
125	5	312	745	650	410	260	30
150	6	364	795	715	410	290	40
200	8	500	860	845	480	350	75
250	10	626	1140	1025	560	410	110
300	12	750	1220	1235	640	490	200
350	14	880	1360	1410	730	540	300
400	16	995	1610	1600	820	600	450
450	18	1125	1710	1765	880	650	600
500	20	1250	2100	2100	950	710	800
600	24	1500	2400	2400	1075	840	1000
700	28	1740	2700	2700	1200	920	1200
750	30	1875	2850	2850	1250	1010	1400
900	36	2250	3250	3250	1550	1200	1700
1000	40	2500	3500	3500	1770	1280	2000
1200	48	3000	4100	4100	2100	1500	2400
1400	54	3500	4650	4650	2450	1800	2800
1500	60	3750	4850	4850	2625	1950	3000

*Other lengths are available to different standards
**These heights also apply to Non-Rising and SCV

NOTE: All these dimensions are indicative only. Please confirm at time of order.

Jindex Pinch Valve Flow Rate Calculations

1. Calculate your Kv or Cv value from the equation
2. Select desired operating point for the valve (% open)
3. Look down the column until your Kv or Cv is found
4. Look across to the left hand margin to read off approximate valve size.

Notes: This chart is for water. Larger values will be required for viscous slurries. Please contact Jindex for help.

US units

$$C_v = Q \sqrt{\frac{D}{\Delta P \times 62.4}}$$

Q = valve flow rate (gpm)
 ΔP = pressure drop through valve (psi)
 D = fluid density (pcf)

SIZE	10	20	30	40	50	60	70	80	90	100
25	12	24	34	42	48	53	56	56	57	57
40	31	82	87	107	124	136	142	144	145	147
50	49	96	138	167	193	213	222	226	227	229
65	82	163	230	283	327	359	375	381	384	387
80	124	247	348	429	495	544	569	578	582	586
100	194	385	544	670	774	851	889	903	909	916
125	304	602	850	1047	1209	1329	1388	1410	1421	1431
150	437	867	1224	1507	1741	1914	1999	2031	2046	2081
200	777	1541	2177	2679	3095	3403	3554	3611	3637	3664
250	1214	2407	3401	4187	4835	5317	5553	5641	5683	5725
300	1749	3467	4698	6029	6963	7656	7997	8124	8184	8244
350	2380	4718	6666	8206	9477	10421	10884	11057	11139	11221
400	3109	6163	8707	10716	12378	13611	14216	14442	14549	14656
450	3934	7800	11020	13565	15668	17226	17993	18278	18414	18549
500	4857	9629	13605	16747	19341	21267	22213	22566	22733	22900
600	6994	13888	19591	24115	27852	30625	31987	32495	32735	32976
700	9520	18874	26666	32624	37909	41684	43537	44229	44556	44884
750	10928	21666	30611	37680	43518	47851	49979	50773	51149	51525
800	12434	24651	34829	42872	49514	54444	56865	57768	58196	58624
900	15737	31199	44080	54260	62666	68908	71970	73113	73654	74196
1000	18428	38518	54420	66987	77365	85089	88852	90283	90931	91600

Metric units

$$K_v = Q \sqrt{\frac{D}{\Delta P \times 1000}}$$

Q = valve flow rate (m³/h)
 ΔP = pressure drop through valve (bar)
 D = fluid density (kg/m³)

SIZE	10	20	30	40	50	60	70	80	90	100
25	11	21	29	36	42	46	48	49	49	50
40	27	53	75	93	107	118	123	125	126	127
50	42	83	118	145	167	184	192	195	197	198
65	71	141	199	245	283	311	325	330	332	335
80	108	213	301	371	428	471	482	500	503	507
100	168	333	471	579	669	736	769	781	787	792
125	263	521	736	905	1046	1150	1201	1220	1228	1238
150	378	750	1059	1304	1508	1656	1729	1757	1770	1783
200	672	1333	1883	2318	2677	2943	3074	3123	3148	3169
250	1050	2082	2942	3621	4183	4599	4804	4880	4916	4952
300	1512	2999	4237	5215	6023	6623	6917	7027	7079	7130
350	2059	4081	5766	7098	8198	9014	9415	9564	9635	9706
400	2689	5331	7532	9271	10707	11774	12297	12492	12585	12677
450	3403	6747	9532	11734	13552	14901	15564	15811	15928	16045
500	4201	8329	11768	14486	16730	18396	19214	19519	19664	19808
600	8050	11994	16946	20860	24092	26940	27669	28108	28316	28524
700	8235	16328	23068	26392	32791	38058	37680	35258	38541	38825
760	8453	18741	26479	32593	37643	41391	43232	43918	44244	44569
800	10756	21323	30127	37084	42829	47094	49188	49989	50340	50710
900	13612	26987	38129	46934	54206	59604	62254	63243	63711	64180
1000	16808	33318	47073	57944	66921	73585	76857	78077	78656	79234

Typical Industries and Applications

Typical Industries

- Mining
- Mineral Processing
- Oil Sands
- Water & Waste water
- Power Stations
- Pulp & Paper
- Chemical
- Concrete
- Effluent Treatment
- Sand and Gravel
- Food
- Sand Mining
- Aluminium Refining
- Steel Casting sand
- Solar Panels

Typical Applications

- Any flow control of a slurry
- Lines with scale problems
- Chemical slurries
- Any ON/OFF where full-bore is required
- Flotation cell level control
- Thickener or clarifier underflow
- Pneumatic conveying
- Oil drilling mud
- 'Ragging' circuits in Pulp & Paper
- Specific Fly Ash Design
- Clinker and Cement Dust
- Lime Dosing Circuits
- ESP dust discharge
- High Pressure Tailings Disposal
- Pressure Filters



Gold Coast Desalination Lime Dosing Valves



Lime Dosing Manual Pinch Valves

References



Size = 21 x 200 & 100's
 Country = USA
 Line pressure = 7 bar
 Duty = Tank Level Control
 Actuation = Pneumatic
 Sleeve = Butyl
 Failsafe = Fail Closed Pneumatic system



Size = 2 x 100 mm (40")
 Country = Russia
 Line pressure = 5 bar
 Duty = Crude Oil Terminal
 Actuation = Electromechanical
 Sleeve = nitrile
 Failsafe = Fail Last position



Size = 306 Various sizes
 Country = Thailand
 Line pressure = Up to 16 bar
 Duty = Metal Refinery
 Actuation = Manual and Pneumatic
 Sleeve = Butyl and Hypalon
 Failsafe = Fail Closed/Last



Size = 4 x 300, 2 x 350, 2 x 450
 Country = Argentina
 Line pressure = 7 bar
 Duty = Tailings disposal
 Actuation = Handwheel & Gearbox
 Sleeve = Natural Rubber
 Failsafe = Fail Last Position



Size = 3 x 750 mm (30")
 Country = Tanzania, Congo
 Line pressure = 5 bar
 Duty = Ball Mill Discharge
 Actuation = Pneumatic Double-Acting
 Sleeve = Extreme Wear Natural Rubber
 Failsafe = Fail Last Position



Size = 26 x 600 mm (24")
 Country = Australia
 Line pressure = 2 bar
 Duty = Tank Cell Discharge
 Actuation = Pneumatic Double-Acting
 Sleeve = Rubber
 Failsafe = Fail Last Position

Jindex Products

- PINCH VALVES
- Pinch Nozzle Valves
- Dart Valves
- Dart Valve Actuation Systems
- Ceramic Control Valves
- Ceramic Knifegate Valves
- Extreme Duty, Custom Valve Design
- High Abrasion Ceramic/ Polyurethane Wear Products
- Pneumatic Failsafe Systems
- Pneumatic Actuation Systems and Positioners
- Rubber, Teflon, Steel Expansion Joints
- Rubber Mining Hoses
- Rubber Pipe Penetration Seals
- Rubber Check Valves [Duck Bills, Inline, High Pressure Ball Check]

Ceramic Knifegate Valves



Check Valves



Pinch Valves

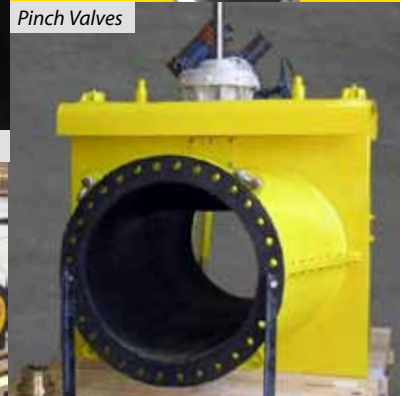

Ceramic Control Chunk Valves



Nozzle Valves



Pneumatic Failsafe Systems



Pipe Penetration Seals



Enquiries:

Ph +61 2 9939 7900

Fax +61 2 9939 7099

Email sales@jindexvalves.com.au

Web jindex.com.au



Expansion Joints



Rubber Mining Hoses



Your local representative is:



千涵國際股份有限公司

張曙光 / 總經理

手機 0927120778 ,E-mail: kflow@seed.net.tw