

DS21 || Differential Pressure Switch

Application

These type series instruments are used as flow-operation safety device in heat carrier oil plants acc. to DIN 32 727 and hot water plants acc. to VdTÜV data sheet flow 100. The flow-operation safety devices consist of a differential pressure device, e.g. an orifice plate, differential pressure switch and adequate shut-off valves. Follow mounting instructions in accordance to application. All instruments of this type series meet these demands. Successful structural testing of type series DS21 is confirmed by the following marks of conformity:

- for flow-operated safety devices
DIN 32 727 DIN record No. 1B012/07
- acc. to VdTÜV data sheet flow 100
TÜV . SW/SB . 07 - 020

Construction and Operation

The monitoring and switching instrument is based on a rugged and uncomplicated diaphragm movement suitable for overpressure, partial vacuum and differential pressure measurements. The operating principle of the system is identical in all three applications.

In a state of equilibrium, the forces of the springs on both sides of the diaphragm are balanced. The pressure or differential pressure to be measured creates an unbalanced force at the diaphragm. This force moves the diaphragm system against the force of the springs for the measuring range until a new equilibrium is reached. When subjected to excessive pressure, the diaphragm rests on metal supporting plates.

A centre-mounted tapped transfers the motion of the diaphragm system to the motion work and to the actuating elements of the microswitches.



Main Features

- High repeatability of switching points
- Long service life
- High overpressure protection
- Structural testing

Functional Scheme

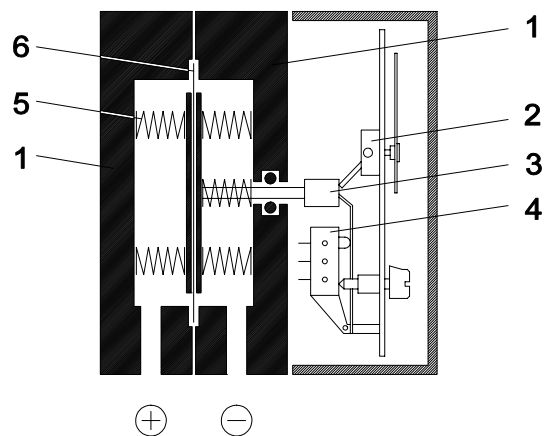

1. Pressure chamber
2. Motion work
3. Tappet
4. Microswitch actuating elements
5. Measuring springs
6. Measuring diaphragm



Specifications

General	
Measuring range	0... 400 mbar up to 0... 6 bar (see ordering code)
Nominal pressure	25 bar
Max. static operating pressure	Acc. to measuring range (see ordering code)
Max. pressure load	One-sided overpressure protected up to nominal pressure on (+) - and (-) side of diaphragm, partial vacuum protected
Perm. ambient temperature	-10... +70°C
Perm. medium temperature	70°C
Protection class	IP 54 acc. to DIN EN 60529
Mounting position	Vertical
Measuring accuracy	± 2.5% FS
Zero adjustment	Located in the dial
Switching Elements	
Contact output	1 or 2 microswitches, 1-channel change-over contacts
Adjustment of switching points	External adjustment by standard value scales smallest adjustable value: approx. 5% FS
Switching hysteresis	Approx. 2.5% FS
Load data / contacts	U _{~max.} = 250 V AC, I _{max.} = 5 A, P _{max.} = 250 VA U _{=max.} = 30 V DC, I _{max.} = 0.4 A, P _{max.} = 10 W
Electrical Connection	Numbered cable, prewired terminal box, 7-channel plug
Pressure Connection	Thread G1/4 female, cutting ring connection for 6, 8, 10, 12 mm Ø tube of brass, zinc steel or chrome nickel steel connection shank G1/4 male DIN EN 837
Measuring System	Diaphragm measuring system, diaphragm of reinforced Viton®
Materials	
Pressure chamber	Aluminium GkAlSi10(Mg), varnished black Aluminium GkAlSi10(Mg) HART-COAT® surface protection Chrome nickel steel 1.4305
Measuring diaphragm	Diaphragm measuring system and gaskets of Viton®
Materials: medium	Stainless steel 1.4310, 1.4305
Materials: housing	Macrolon
Weight	Pressure chamber of Aluminium = 1.2 kg, pressure chamber of 1.4305 = 3.5 kg
Mounting	Wallmounting - 3 fastening elements Panel mounting - panel mounting kit DZ11 ø132 mm Pipe mounting, pressure connections = (+), (-) symbols - by screwed-in cutting ring or clamping ring connection - by screwed-in connection shank acc. to DIN EN 837 for nipple fitting acc. to DIN 16284

Dimensions (all units in mm unless otherwise stated)

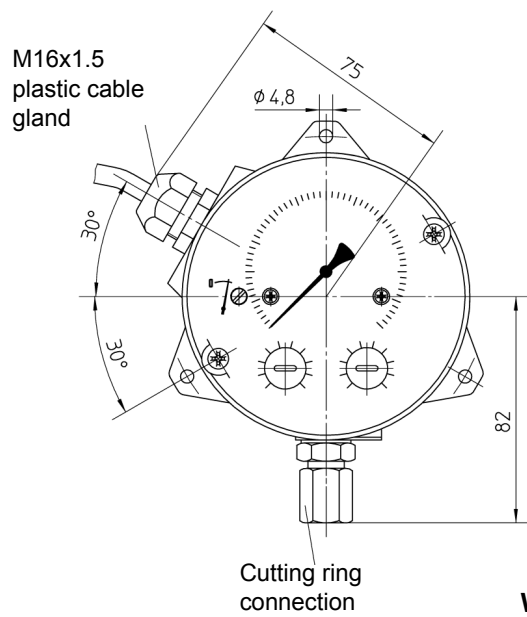

DS21
Wallmounting
(standard)

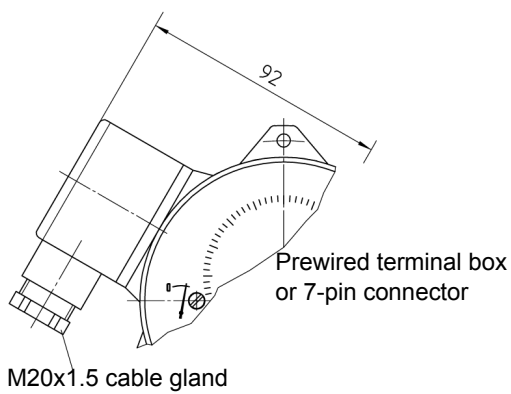
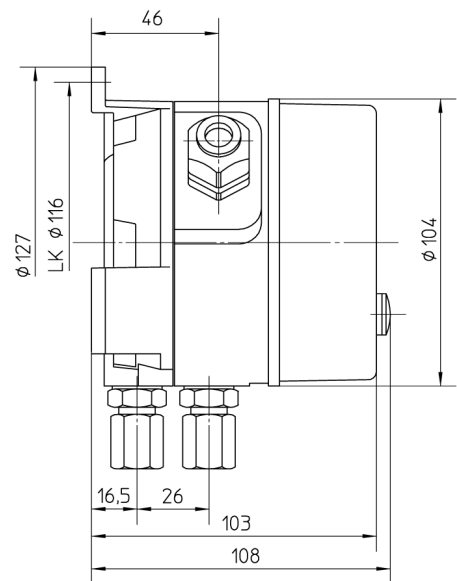

Variants of Electrical Connection

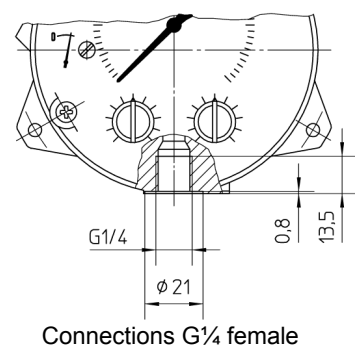

Variants of Process Connection

Ordering Code

Differential Pressure Switch

DS21

		0					#	#	#	0
--	--	---	--	--	--	--	---	---	---	---

Range	Max. static pressure									
0 ... 400 mbar	6 bar	>	8	3						
0 ... 0.6 bar	10 bar	>	0	1						
0 ... 1 bar	16 bar	>	0	2						
0 ... 1.6 bar	16 bar	>	0	3						
0 ... 2.5 bar	16 bar	>	0	4						
0 ... 4 bar	16 bar	>	0	5						
0 ... 6 bar	16 bar	>	0	6						
Application										
Thermal oil DIN 32727 / Hot water / Flow 100		>	0							
Pressure Chamber										
Aluminium		>		A						
Aluminium HART COAT®		>		D						
Chrome-nickel-steel 1.4305		>		W						
Pressure Connection										
Female thread G1/4		>	0	1						
Cutting ring fitting of steel for 6 mm tube		>	2	0						
Cutting ring fitting of steel for 8 mm tube		>	2	1						
Cutting ring fitting of steel for 10 mm tube		>	2	2						
Cutting ring fitting of steel for 12 mm tube		>	2	3						
Cutting ring fitting of 1.4571 for 6 mm tube		>	2	4						
Cutting ring fitting of 1.4571 for 8 mm tube		>	2	5						
Cutting ring fitting of 1.4571 for 10 mm tube		>	2	6						
Cutting ring fitting of 1.4571 for 12 mm tube		>	2	7						
Switching Elements										
1 adjustable microswitch		>		A						
2 adjustable microswitches		>		B						
Electrical Connection										
1 m numbered cable, prewired		>		1						
2.5 m numbered cable, prewired		>		2						
5 m numbered cable, prewired		>		5						
Prewired terminal box		>		K						
GL approved model, 3 m supply cable H07 RNF		>		Z						