



PELLERMIX SIDE ENTRY MIXERS



The Mixing Specialists



PELLERMIX SIDE ENTRY MIXERS

Standard Features

PELLERMIX Side Entry Mixers are designed for solids suspension and mixing. PELLERMIX's proven side Entry design assures you of a machine that will perform to the required task and give many years of reliable service. The following is some major advantages in using a PELLERMIX Side Entry Mixer:

- Fast and Easy Seal Change while tank is full
- No Need to remove V-Belts/tooth belts to access seal
- V-Belts or Tooth Belt Drives available
- Fully enclosed and sealed bearings with a fatigue life of more than 100,000 hours
- No in Tank Bearings
- Choice of Wetted parts materials
- Double mechanical Seals with lubricators and Explosion proof motors available
- Variable Stand configuration to suit the terrain around the tank



Applications

Food Industry	Cocoa Butter Blending and storage
Edible Oil Industry	Crude Oil Storage, Bleaching, Winterization in horizontal tanks
Transportation Industry	Heat Transfer, Solids Suspension mixer.
Petrochemical Storage	Crude Oil Storage, heat exchanging and Blending
Ceramic Industry	Slip Storage

Special Options

- Leak Detector Sensor Alarm
- Storage tank low level cut off
- Lock off Unit for full tank seal change
- Vibration Monitoring
- Swivel Direction sealed shaft socket



Materials, Finishes and Coatings

- SUS 304
- SUS 316
- Teflon Coating
- Stainless steel with 120 Grit Finish
- Carbon Steel with Epoxy Coated
- Halar Coating
- Ceraflake Coating
- Carbon Steel
- SUS 316 L
- Hastalloy
- Stainless steel Glass bead short grade 4 or 8
- Rubber Coating

Mixer Seal Isolation Device



The Pellermix seal Isolation device work through a plug and seal design. The device allows for the seal change whilst the tank is full.

The Plug can me machine for metal on metal sealing or soft sealing.

It is recommended for products with incompressible grid that a soft seal seat be used.

The same mechanism can be used for stuffing box seal and mechanical seals.

Vibration Monitoring

Hazardous Area rated wireless vibrating monitoring devices can be fitted to Pellermix bearing housing to monitor bearing performance and product impact on the mixer. These devices are easily install and removed and can be rotated through different mixers in order to obtain a more efficient maintenance system.





Mixer Power Selection

The power required for mixing will vary for each application. Pellermix has standard calculation methods to determine the optimum size mixer for each application. For most tanks over 1000 m³ then the power required per 1000m³ ranges from 1 kW to 5 kW depending on the application.

The Power factor can then be used to correlate the total number of mixers and power of mixers for the tank. The Power factor is the Power required / 1000 m³ of tank volume.

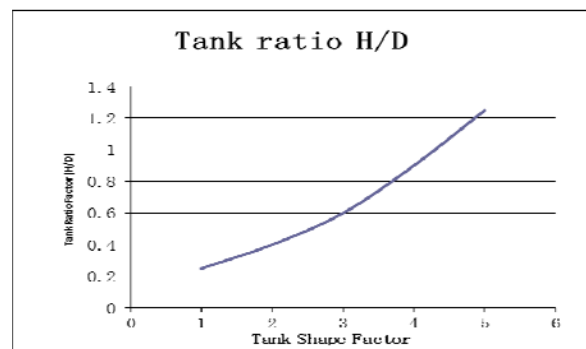
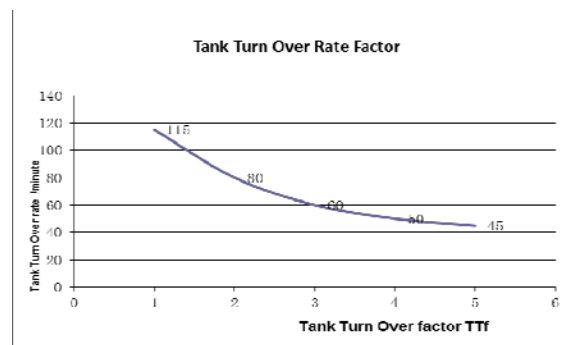
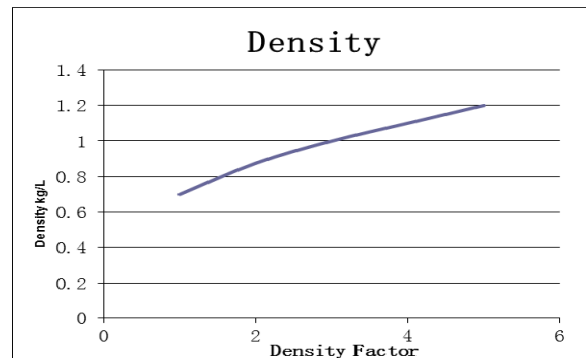
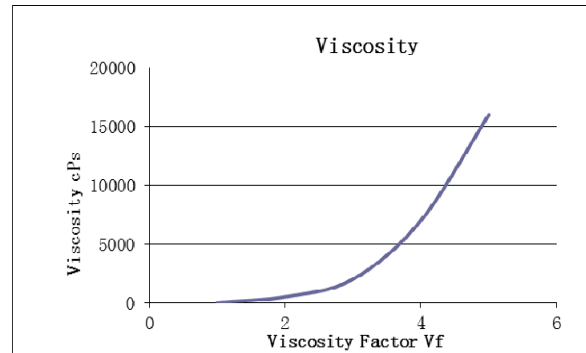



Impeller Types



Marine Impeller



Flat Pitch Impeller



45 Pitch Turbine

Tooth Belt Driven Side Entry Mixers

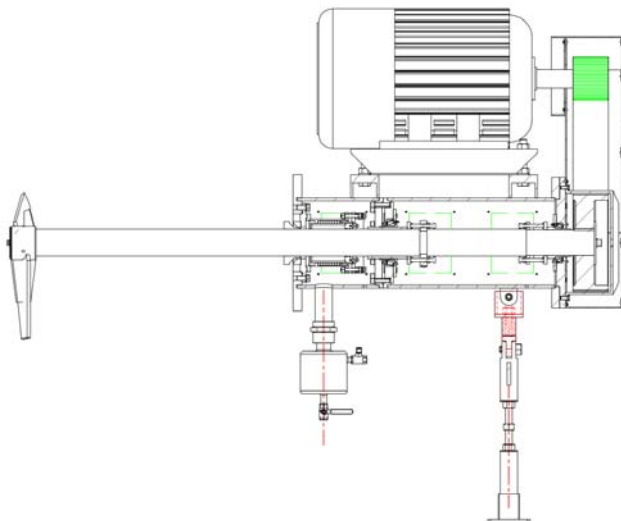

Why use Tooth Belt Drive Side Entry mixers?

- Maintenance of parts are easily sourced compared to a gear drive
- Tooth Belts provide long service life compared to V Belts and some gear drives
- No Gear drive lubrication concerns.

Swivel Type Side Entry Mixers

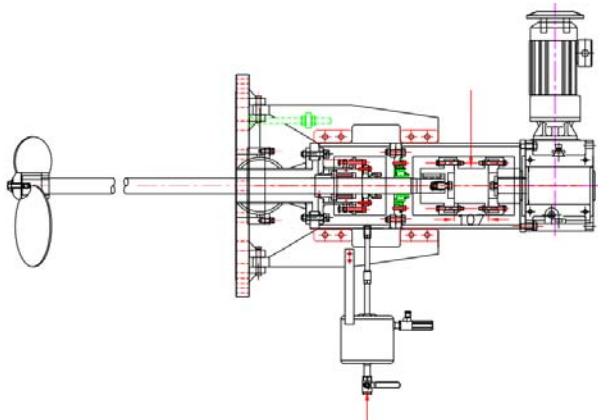

Why use Swivel Type Side Entry mixers?

- Allows you to direct the mixer stream up to 30 degrees each side of the mount
- Can clear sedimentation build up.
- Optimise mixing of tank through strategic directing of the mixer.



Pellermix Pty Ltd
Darwin, Australia

Email: info@pellermix.com
web: www.pellermix.com

All rights: Coefase Pty Ltd (Australia)