



# Globe Control Valve

---

Valves with  
Pneumatic  
Electrical  
Actuator



# GFlo

## Body sub-assembly

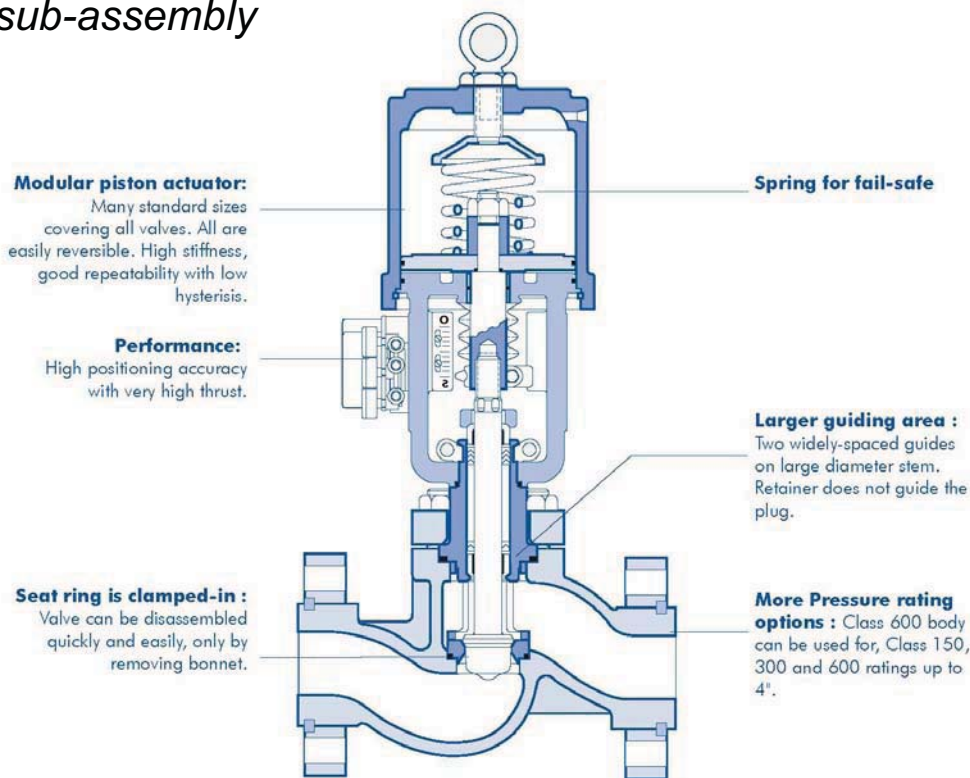

Figure 1: GFlo Body Assembly, Class 150, 300, and 600

Superior performance in liquids and gaseous services is the hallmark of GFlo. Easy, quick and economical maintenance is making GFlo globe control valve more user friendly. The spring cylinder actuated GFlo imparts stiffness and maintains very high precision in positioning, strong response, repeatability and controlled high speed are the characteristics absent in diaphragm operated control valves. GFlo has the thrust capability to shutoff against higher fluid pressures as it can handle up to 150 psg / 10.30 Bar air supply. Valve closure is totally dependent on springs in most diaphragm actuators. The unique design of GFlo enables the spring, fluid pressure and supply air pressure to combine and achieve an extremely tight shutoff. A self aligning seat ring adds to and further improves the shutoff capability.

Galling at cage is the culprit in many common maintenance with globe valves because of the close metal-to-metal contact between plug & cage. The GFlo has two top heavy duty stem guides. Contact between the plug and seat retainer is completely avoided in GFlo. Easy and quick maintenance is permitted due to clamped-in seat and top entry trim. Inventory costs are reduced as most parts needed are interchangeable. Against comparable diaphragm actuators, this actuator is lighter, smaller and very easy to handle.

With MVA 's Quick-Valve express, Deliveries are immediate in standard GFlo because of its quick manufacturing process.

GFlo are durable, reliable and wear resistant globe valve.



## *Advantages and Features*

<b>Advantages</b>	<b>Features</b>
<b>Obeys the command</b>	Stringent, high-thrust cylinder actuator. Accurate positioning. High repeatability. Ensured Response. Controlled, high-quick stroking action.
<b>No Sticking, no shutting down of process</b>	Cage guiding eliminated. Double stem guiding does not come in contact with operating fluid. Sufficient clearance between plug head and seat retainer.
<b>Pleasure to maintain</b>	Top-entry servicing. Clamped-in seat ring. Evenly and controlled torqued compressed gaskets. Separable flanges. High degree of parts interchangeability. Compact, lightweight design.
<b>No leakage on closure</b>	High-thrust, spring-cylinder actuator. Self-aligning seat ring. Shutoff assisted by fluid pressure, cylinder spring and cylinder pressure. Spring takes valve to desired position, air provide additional force.
<b>Tougher than the Toughest</b>	Anti Corrosion construction. High thrust overcomes high pressures. Anti-cavitation and noise trim options. Heavy-duty plug stem.
<b>Easy installation, Compact body</b>	Compared to diaphragm actuator is compact in design and lower center of gravity. Light weight so less pipe stress from static and dynamic loads. Separable end flanges allow the valve to be installed in many orientations and compensate for flange misalignment.
<b>Minimal life-time cost</b>	Excellent interchangeability between sizes and other MVA products. Valve design minimizes requirements for stocking spare parts. Stiff, heavy-duty parts provide extended life. Actuator design allows simple, easy maintenance.



# GF10

## Parts

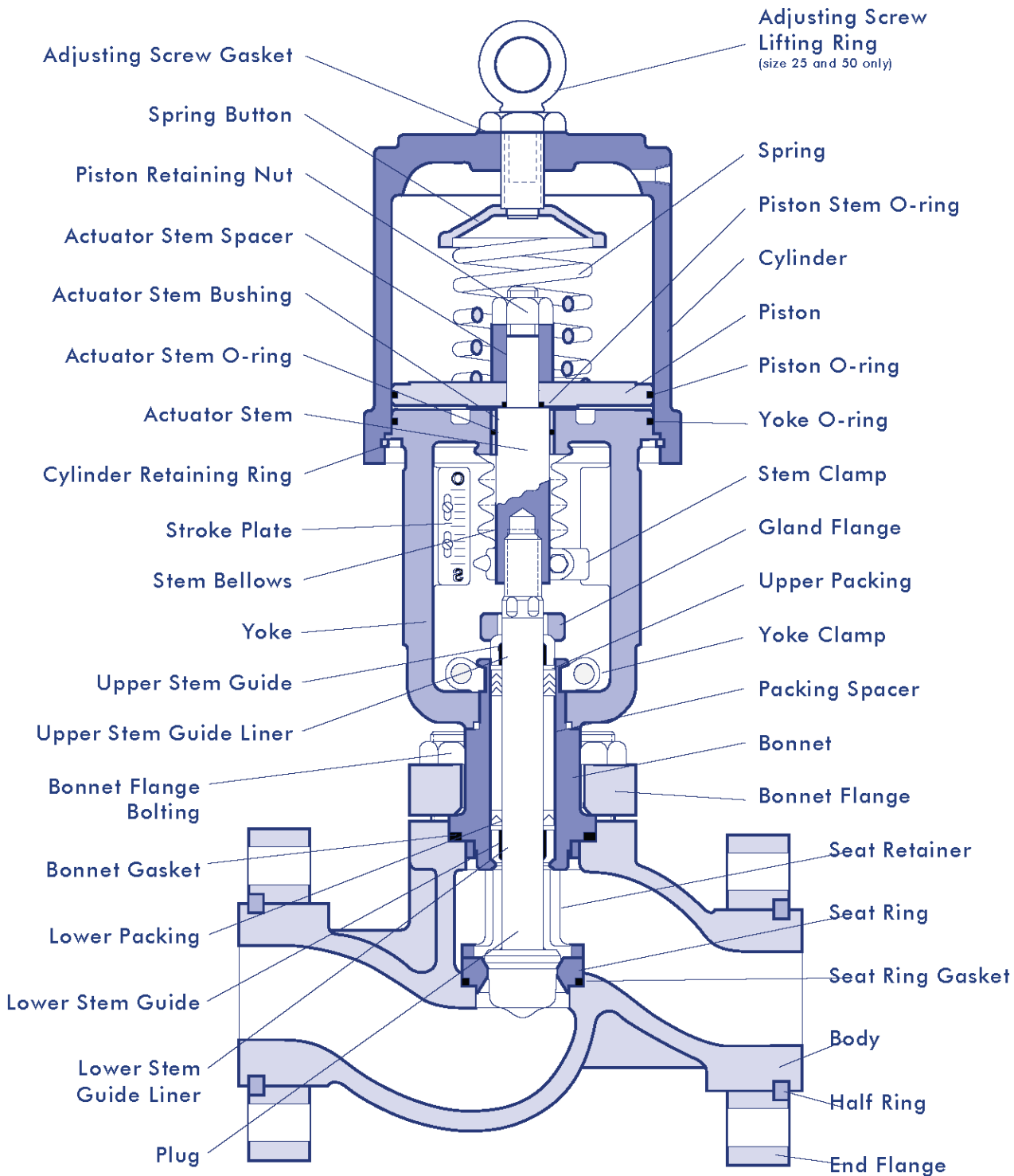

# GFlo

## Body configurations

Figure 3: Globe-style body configuration

Smooth, Streamlined, constant area internal passages with no pockets, permitting high capacity with minimum turbulence is what GFlo-style bodies feature. Manufactured in expensive stainless or alloy steels, they are designed with nearly constant wall thickness, providing lower weight and cost.

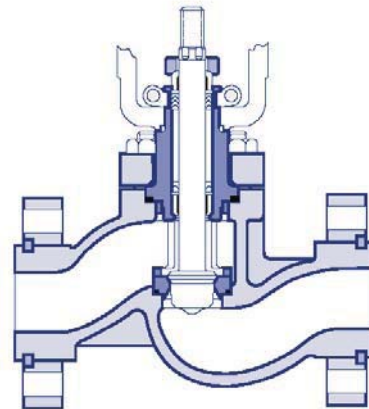

Figure 4: Three-way body configuration

For either combining or diverting flow services, three-way bodies are used. Owing to MVA's excellent design, high interchangeability; even a standard GFlo valve converts easily to three-way service with the addition of three-way adopter, upper seating, two gaskets, three-way plug and longer bonnet flange studs.

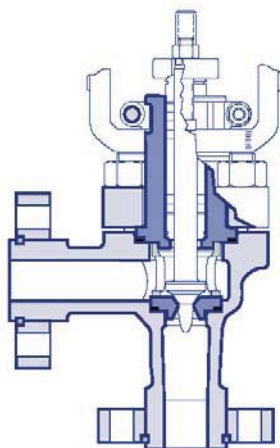
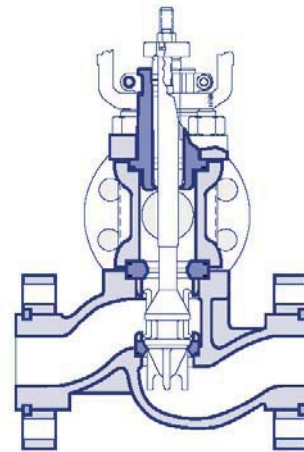

Figure 5: Angle-style body configuration

With all other valve parts remaining the same, the angle-style GFlo is completely interchangeable with two-way globe style except the body and the 1 1/2 inch seat ring.

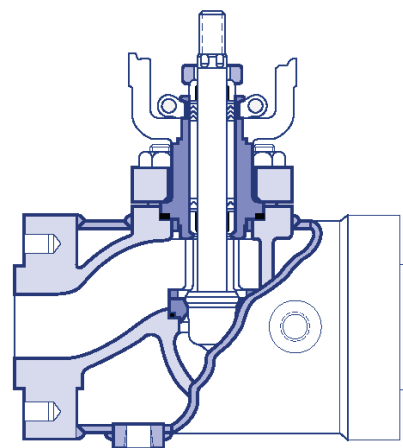

Figure 6: Steam Jacketed body configuration

GFlo use a standard globe style body for steam jacketed with oversize flange for a full jackets. For partial jacket, standard size flanges are used.

# GFlo

## End connections, flanges and bolting

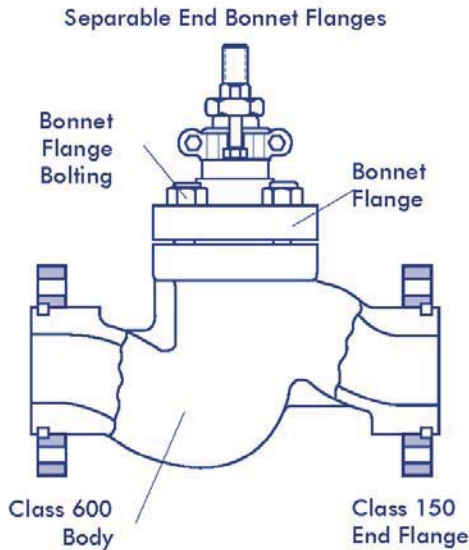

Figure 7:  
Separable End and Bonnet Flanges

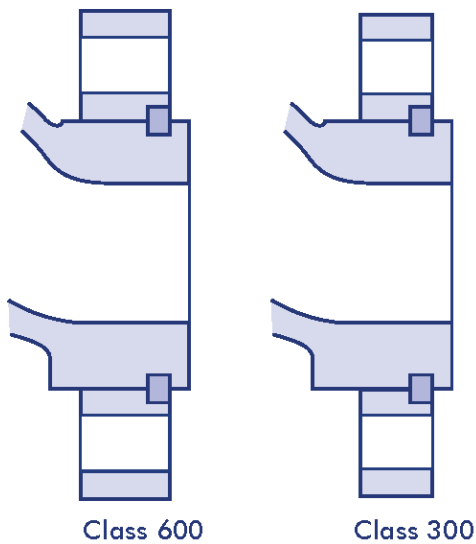

Figure 8: End Flanges

- (a) ANSI B16.10 Class 600 globe valves
- (b) ANSI/ISA S75.03, 1985
- (c) MVA standard
- (d) MVA standard to 6-inch, above 6-inches per ANSI B16.10, 1986.

Raised face for either separable or internal flanges comes standard with GFlo body facings. For achieving better sealing spiral grooves are serrated over flange faces. If required other optional facings like, smooth face, ring joint, large and small groove are machined.

### Separable End Flanges

On a GFlo, interchangeable separable flanges are standard for valve body up to 4" in class 150, 300 and 600 ANSI rating and for 6" and 8" bodies in class 300 and 600. By simply changing the end flanges which are separable, Class 600 body can be adapted for Class 150, 300 or 600 services. Stainless steel can be specified if the process atmosphere or extreme temperatures command it. Separable flanges are normally furnished in carbon steel for cost saving.

### Bonnet Flange

Bonnet flanges have the same separable design as the end flange. Normally carbon steel or stainless steel (if required) can be used as bonnet flange.

### Bonnet Flange Bolting

304 and 316 stainless steel studs and bolts are used which are suitable for  $423^{\circ}$  to  $1500^{\circ}$  F /  $-253^{\circ}$  to  $816^{\circ}$  C. temperature. These temperature limits are for maximum pressure allowed by ANSI B16.34, 1988.

Table 1: End Connections

End Connection	Valve Size (inches)	Class	Standard Face -to-Face	Optional Face -to-Face
Separable Flange	$1/2$ - 4	150 - 600	ANSI (a)	ISA
	6-8	300-600	ISA (b)	
Integral Flange D Steel & Alloys	$1/2$ - 48	150	ISA	
	$1/2$ - 48	300 - 600	ISA	
	$1/2$ - 24	900 - 2500	VS(d)	
Screwed	$1/2$ - 2	150 - 600	ANSI	
	$1/2$ - 2	900 - 2500	VS(c)	
Socketweld	$1/2$ - 2	150 - 600	ANSI	ISA
	$1/2$ - 2	900 - 2500	VS (c)	
Buttweld	$1/2$ - 4	150 - 600	ANSI	ISA
	6 - 36	150 - 600	ISA	
	$1/2$ - 24	900 - 2500	VS(d)	





# GFlo

## Gaskets and Clamps

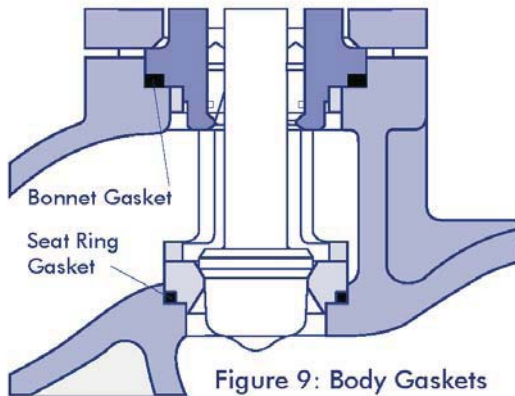

Figure 9: Body Gaskets

The GFlo is uniquely designed with the bonnet and seat ring gaskets fully protected. Since the bonnet sits metal-to-metal in the body, the bonnet gasket compression is determined by the depth of the gasket step on the bonnet, which is machined to provide the required gasket compression.

When the bonnet is fully installed, force is transmitted through the seat retainer to secure the seat ring in its position. The body, seat retainer and seat ring are all machined to close tolerances to provide the proper gasket compression. Unlike the bonnet, the seat ring does not sit in the body, allowing the small clearance to compensate for manufacturing tolerances and thermal expansion.

Table 3: Gasket Specifications

	Type	Gasket Material	Maximum Gasket Temp. °F / °C	Minimum Gasket Temp. °F / °C
Standard Gaskets	Flat	Teflon (TFE)	350 / 177	-200 / -130
	Spiral Wound	304 S.S./AFG	750 / 400	-20 / -30
	Spiral Wound	316 S.S./AFG	1000 / 538	-20 / -30
Alternate Gaskets	Flat	AFG	600 / 318	-20 / -30
	Flat	KEL-F	350 / 177	-320* / -196*
	Flat	Teflon (FEP)	400 / 204	-320 / -196
	Flat	Grafoil**	1500** / 816**	-320 / -196
	Spiral Wound	316 S.S./Grafoil**	1500** / 816**	-320 / -196
	Hollow O-ring	Inconel X-750	1500 / 816	-20* / -30*

\*Lower temperature available upon request.

\*\*Limited to 800 °F / 427 °C for oxidizing service.

### Yoke Clamps

Usually the actuator is attached to the GFlo body assembly with two precision cast, stainless steel yoke clamps, although in some cases the actuator is bolted directly to the bonnet. Each clamp has an inclined plane surface which, when bolted together, securely fastens the actuator yoke to the bonnet.

MVA'S clamp design allows easy removal under maximum corrosive conditions. Associated bolts and locknuts are provided in plated carbon steel, but if required, stainless steel is also available.

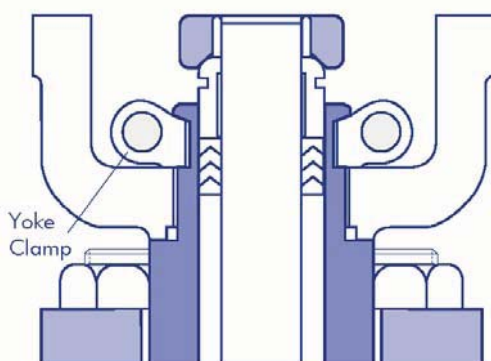
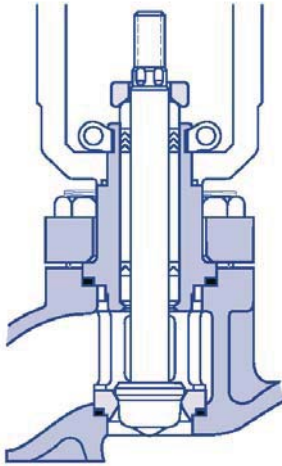

Figure 10: Yoke Clamp

# GFlo

## Bonnets

Figure 11 : GFlo Bonnet Types



**Standard Bonnet**

The GFlo body & bonnet are of the same material and can handle temperatures from -20 °F to 750 °F / -30 °C to 400 degree centigrade.

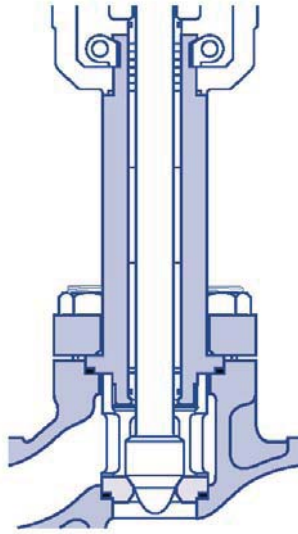

**Extended Bonnet**

Prime function of extended bonnet is to protect the packing from excessive heat or cold, aiding the optimal functioning of the valve. It is from carbon steel for temperatures from -20 °F to 800 °F / -30 °C to 427 °C and of 304 or 316 stainless steel for -150 °F to 1500 °F / -100 °C to 816 °C.

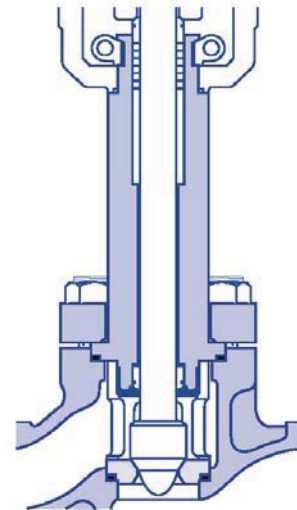

**Cold Box  
Extended Bonnet**

The Cold box extended bonnet allows stagnated moderate temperature gas to form in the bonnet, while protecting the packing from the operating fluid. Usually manufactured from 304 or 316 stainless steel, it handles temperatures down to -423 °F / -253 °C. Standard construction consists of stainless steel bonnet flange and bolting.

### **Metal Bellows Seal Bonnet**

Whenever service fluid leak to the atmosphere needs reduction to an absolute minimum, metal bellows seal comes in handy. The standard metal bellows seal is rated for operation in processes ranging in temperature from -320 °F to 1100 °F / -196 °C to 593 °C and pressures to 1100 psi g / 75.9 Bar g. This flexible metal bellows is usually constructed of Inconel 625, SS 304/316. Metal bellows can also be furnished in Hastelloy C-22.

The bellows design seal allows for outside pressure to minimize bellows squirm, prolonging bellows life.

### **Metal Bellows Seal Bonnet**

Protection is provided by the metal bellows seal against the unwanted packing leakage to atmosphere in processes involving caustic liquids and gases.

The compact, lightweight design makes it ideal for services below 650 °F / 343 °C and 310 psig / 21.4 Bar G. The precision formed bellows is available in Inconel or Hastelloy C materials.

Since bellows seals are designed for special service conditions and not for valve's design class, it is required to specify the complete service conditions.





# GFlo

## Packing & Guides

Being deeper than the conventional boxes, the **MVA** packaging boxes offer the following advantages:

Advantages of **MVA** packing boxes over the conventional types of boxes:

1. Space between the wiper set and the main upper packing avoids contamination of upper packing. The upper set is positioned very far from wiper set to avoid contact with any part of the plug stem which is exposed to the flowing medium. Wiper set wipes clean any fluid on the plug stem.
2. Bonnets are designed to permit wide variety of packing styles, including double set of packing, without changing bonnets.
3. When used with GFlo, large plug stem diameter and two widely-placed stem guides provide exceptional guiding.
4. Lined by Grafoil, the stainless steel provides superior guiding over wide temperature ranges and completely eliminate guide/stem galling. A variety of guides are available for various applications, including solid brass, Stellite and glass-filled Teflon-lined stainless steel.

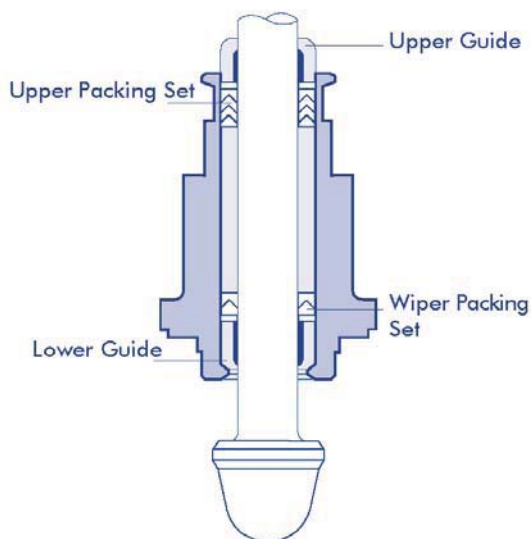

Figure 12: Typical Teflon V-ring Arrangement

Table 4: Guides

Standard Materials	Max. Temp.	Min. Temp.	Maximum Pressure
Grafoil lined SS***	1500°F / 816°C	-320°F / -196°C	1400 psig/96.6 Barg thru 2-inch 1000 psig/69.0 Barg 3 thru 4-inch 850 psig/58.6 Barg 6-inch & up
Glass-loaded			150 psig/10.3 Barg @100°F/38°C
Teflon-lined S. S.	350°F / 177°C	-423°F / -253°C	100 psig/6.9 Barg @ 350°F/177°C
Solid Bronze	500°F / 260°C	-423°F / -253°C	Same as body
Solid Stellite	1500°F / 816°C	-423°F / -253°C	Same as body

Table 5: Packing

Bonnet Type	Packing Material	Service Fluid Temperature Limitation °F / °C
Standard** Bonnet	Teflon, Teflon/AFP and Glass-filled Teflon	500 / 260
	Graphite/AFP	750 / 400
	Graphite/AFP, Inconel wire	750* / 400*
	Grafoil***	750* / 400*
Extended** Bonnet	Teflon, Teflon/AFP and Glass-filled Teflon	600 / 316
	Graphite/AFP	1200 / 650
	Graphite/AFP, Inconel wire	1200 / 650
	Grafoil***	1500 / 816
Cryogenic Extended Length**		
15, 18-inch	Teflon	-320 / -196
24, 27-inch	Teflon	-423 / -253

\* Temperatures assume environmental temperature is less than 90 °F / 32 °C. 8 thru 12-inch Class 900-2500 handles temperatures to 850 °F / 454 °C.

\*\* ANSI B16.34 specifies acceptable pressure temperature limits for pressure retaining materials. Consult the factory for additional information.

\*\*\* Do not use Grafoil above 800 °F / 427 °C in oxidizing service such as air or oxygen. The use of Grafoil packing may require oversize actuators or heavier springs due to added friction.

# GFlo

## Characteristics & Trim types

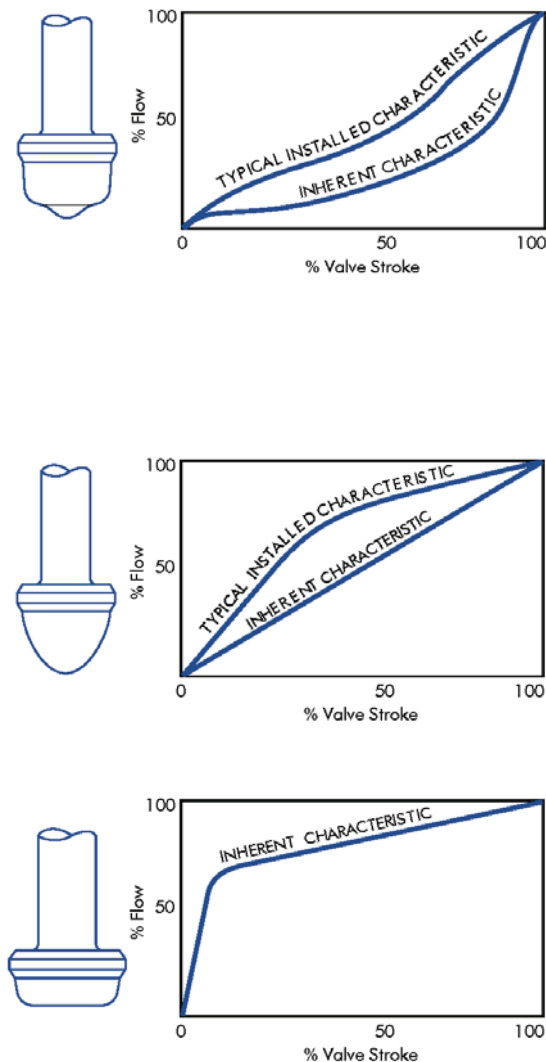

Figure 13: Flow Characteristics

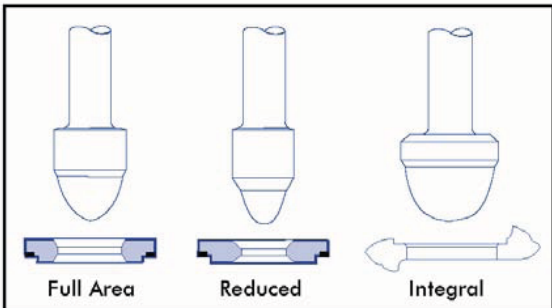

Figure 14: Typical Trim Types

### Equal Percentage

Equal percentage characteristic is the most commonly used in process control today.

**The change in flow per unit of valve stroke is directly proportional to the flow occurring just before the change is made.**

While the flow characteristic of the valve itself may be equal percentage, most control loops will produce an installed characteristic approaching linear when the overall system pressure drop is large relative to that across the valve.

### Linear

On those systems where the valve pressure drop is a major portion of the total system pressure drop, linear plugs are used.

**Linear inherent characteristic produces equal changes in flow per unit of valve stroke regardless of plug position.**

### Quick Open

For on-off service, quick open plugs are employed. They are primarily designed to produce maximum flow quickly.

### Trim Types

1. **Standard full area trim** provides maximum CV.
2. **Reduced trim** is available in a wide variety of sizes when lower CV's and large bodies are required.
3. **Integral trim** uses a special seat machined into the body and an oversized plug to provide additional CV beyond the capabilities of full area trim.

GFlo's valves can be converted from any trim type to another since all seat rings and plugs with a given size and pressure class are completely interchangeable. Integral trim is available by removing the seat ring and by changing the plug.

# GFlo

## Standard & pressure-balanced trim

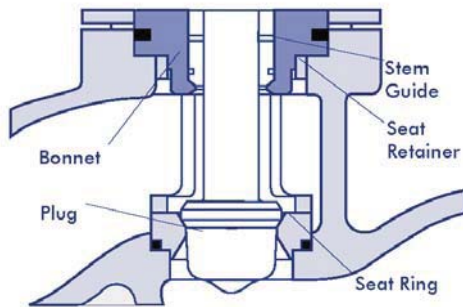

**Figure 15: Standard Trim**

The GFlo trim is uniquely designed to avoid the difficulties associated with screwed-in seats and cage-guiding. Removal of the seat is easy even under extremely corrosive conditions because the seat ring is just clamped into the body by the bonnet and seat retainer.

GFlo plugs are double-stem guided, avoiding contact between the seat retainer and plug, unlike cage-guided trims that easily gall and stick. Because no contact is made with the plug, the retainer can be constructed of stainless steel rather than costly hard materials. The flow characteristic is determined by the plug contour, and not by the opening in the retainer.

Low-noise seat designs have been developed for better noise control in standard GFlo valves.

### Metal Seats

Class IV shutoff are handled better with metal seated valves. This class calls for maximum permissible seat leakage of 0.01 percent of rated valve capacity. All MVA valves are seat leak tested after assembly and generally are substantially lower in leakage than called by the std.

**Table 6: Standard Seal Temperature Ranges**

Teflon Sleeve	-320° F / -196° C @ full rating or +300° F / 150° C @ 150 psig / 10.3 Barg
NiResist Piston Rings	-20° to 800° F / -30° to 427° C
Buna-N O-ring	-60° to 250° F / -51° to 121° C
Rene 41	800° to 1600° F / 427° to 871° C
Spring energized TFE	-365° to 575° F / -221° to 302° C
Viton	-40° to 437° F / -40° to 225° C

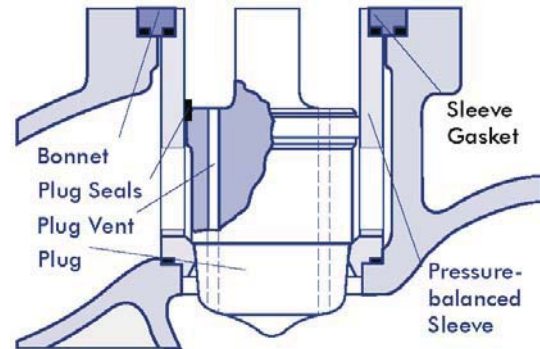
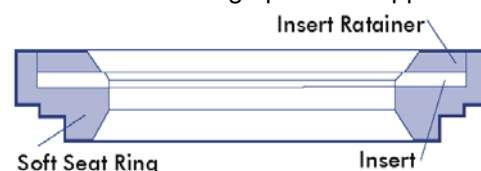

**Figure 16: Pressure-balanced Trim**

Aligning the seat ring with the plug during assembly gives exceptional seat tightness. Additional seat tightness using metal seats is also available. In case of very high pressure drops, pressure-balanced trim is used to reduce the thrust necessary to stroke the plug by reducing the trim off-balance area. Because the pressure-balanced plug fits closely to the retainer, this trim should only be used in generally clean services. Flow direction is under the plug for fail-closed and over the plug for fail-open. The seal area less the stem area is designed to be slightly larger than the seat area, thus the plug is off-balanced to close for flow under the seat and off-balanced to open for flow over the seat.

### Soft Seats

In applications needing ANSI Class VI "Bubble-tight" shutoff, the GFlo soft seat is used. The design consists of an elastomer sandwiched between two metal pieces. The assembled soft seat is interchangeable with the hard seat for a given size and pressure rating. Inserts are often constructed of Teflon, therefore, maximum temperature should be below 300 °F / 150 °C at 290 psi g / 20 Bar G. For temperatures below -85 °F / -65 °C, Teflon soft seats can be used in high pressure applications.





# GFlo

## Trim material & Data

**Table 7: Material Hardness Ratings**

Trim Material	Hardness Rockwell C	Corrosion*Resistance
316 S.S.	8	Excellent
Stellite No. 6	44	Good to Excellent
416 S.S.	40	Fair
440C S.S.	56	Fair
17-4 PH	40	Excellent
Colmonoy	45-50	Fair to Good
Tungsten Carbide	72	Good on Bases Poor on Acids

\* General rule only. Check specific application.

## Trim Materials & Data

Except in case of special alloy bodies where trims are furnished in the same metal as the body, MVA's standard plug and seat ring material is 316 stainless steel. A good range of services are successfully handled by stainless steel trim. Nevertheless, a general rule is to consider hard trim for all choked flow conditions or for temperatures above 600 °F / 316 °C. MVA stocks Stellite no. 6 for many valve trim parts. This material offers a good combination of relative hardness and corrosion resistance. Special alloys, such as Alloy 20, Hastelloy C and Monel, are also available.

**Table 8: Standard Unbalanced Valve/Actuator Data**

Valve Size (inches)	Rating Class	Full Area Trim Size	Seat Area (sq. in.)	Stem Dia.	Stem Area (sq. in.)	Std. Act. Size*	Stroke (inches)
1/2	150-600	.50	.196	.562	.248	25	.75
3/4	150-2500	.72	.405	.562	.248	25	.75
1	150-600	.81	.518	.562	.248	25	.75
1	900-1500	.81	.518	.562	.248	25	.75
1	2500	.72	.405	.562	.248	25	.75
1 1/2	150-600	1.25	1.23	.875	.601	25	1.00
1 1/2	900-1500	1.25	1.23	.875	.601	50	1.00
1 1/2	2500	1.00	.785	.875	.601	50	.75
2	150-600	1.62	2.07	.875	.601	25	1.50
2	900-1500	1.62	2.07	.875	.601	50	1.50
2	2500	1.25	1.23	.875	.601	50	1.00
3	150-600	2.62	5.41	1.125	.99	50	2.00
3	900-1500	2.62	5.41	1.5	1.77	100	2.00
3	2500	2.00	3.14	1.125	.99	100	1.50
4	150-600	3.50	9.62	1.125	.99	50	2.50
4	900-1500	3.50	9.62	1.5	1.77	100	2.50
4	2500	2.62	5.41	1.5	1.77	100	2.00
6	150	5.00	19.63	1.125	.99	50	3.00
6	300-1500	5.00	19.63	2.0	3.14	100	3.00
6	2500	4.00	12.57	2.0	3.14	100	3.00
8	150	6.25	30.68	1.5	1.77	100	4.00
8	300-600	6.25	30.68	2.0	3.14	100	4.00
8	900-1500	6.25	30.68	2.5	4.91	100	4.00
8	2500	5.00	19.63	2.5	4.91	100	3.00
10	150	8.75	60.13	2.0	3.14	100	4.00
10	300-600	8.75	60.13	2.5	4.91	100	4.00
10	900-1500	8.00	50.27	3.0	7.07	100	4.00
10	2500	6.25	30.68	3.0	7.07	100	4.00
12	150	9.50	70.88	2.0	3.14	100	4.00
12	300-600	9.50	70.88	3.0	7.07	100	4.00
12	900-2500	8.00	50.27	3.0	7.07	100	4.00
14	150	11.00	95.03	3.0	7.07	100	4.00
14	300-600	11.00	95.03	3.0	7.07	100	4.00

\* Minimum standard actuator size. Oversized actuators may be required for large pressure drops.

**For higher/other sizes, please contact factory**



# GFlo

Trim data, Hard facing

**Table 9: Standard Pressure-balanced Valve/Actuator Data (inches)**

Valve Size (inches)	Rating Class	Full Area Trim Size*	Seat Area (sq.in.)	Stem Dia. (sq.in.)	Stem Area (sq.in.)	Sleeve Area (sq.in.)	Off-balance Area sq.in.		Standard Actuator Size**	Stroke (inches)
							Flow under To Close	Flow over To Open		
2	600	1.62	2.07	.562	.248	2.58	.26	.51	25	1
2	1500	1.62	2.07	.562	.248	2.41	.09	.34	50	1
2	2500	1.25	1.23	.562	.248	1.55	.07	.32	50	1
3	600	2.62	5.41	.875	.601	6.77	.76	1.36	50	1.5
3	1500	2.62	5.41	.875	.601	6.49	.48	1.08	100	2
3	2500	2.0	3.14	.875	.601	3.86	.12	.72	100	1.5
4	600	3.5	9.62	.875	.601	11.41	1.19	1.79	50	2
4	1500	3.5	9.62	1.125	.994	11.41	.80	1.79	100	2
4	2500	2.62	5.41	1.125	.994	6.77	.37	1.36	100	2
6	150	5.0	19.63	1.125	.994	22.69	2.06	3.06	50	2.5
6	600	5.0	19.63	1.5	1.77	23.76	2.36	4.13	100	2.5
6	1500	5.0	19.63	1.5	1.77	22.69	1.29	3.06	100	2.5
6	2500	4.0	12.57	1.5	1.77	15.03	.69	2.46	100	2.5
8	600	6.25	30.68	1.5	1.77	35.78	3.33	5.10	100	3
8	1500	6.25	30.68	2.0	3.14	35.78	1.96	5.10	100	4
8	2500	5.0	19.63	2.0	3.14	23.76	.99	4.13	100	3
10	600	8.0	50.27	2.0	3.14	58.36	4.95	8.09	100	3
10	1500	8.0	50.27	2.5	4.91	58.36	3.18	8.09	100	4
10	2500	6.25	30.68	2.5	4.91	37.12	1.53	6.44	100	4
12	600	9.5	70.88	2.5	4.91	82.52	6.73	11.64	100	4
12	1500	9.5	70.88	2.5	4.91	79.53	3.74	8.65	100	4
12	2500	8.0	50.27	2.5	4.91	56.75	1.57	6.48	100	4
14	150	11.0	95.03	2.5	4.91	108.43	8.49	13.40	100	8
14	600	11.0	95.03	3.0	7.07	106.05	3.95	11.02	100	8
14	1500	11.0	95.03	3.0	7.07	103.87	1.77	8.84	100	8
16	600	12.75	127.68	3.0	7.07	148.49	13.74	20.81	100	8
16	1500	12.75	127.68	3.0	7.07	140.61	5.86	12.93	100	8

\* This data does not apply to Channel Stream or NR Series trim.

\*\* Minimum standard actuator size. Oversized actuators may be required for large pressure drops.

For higher/other sizes, please contact factory

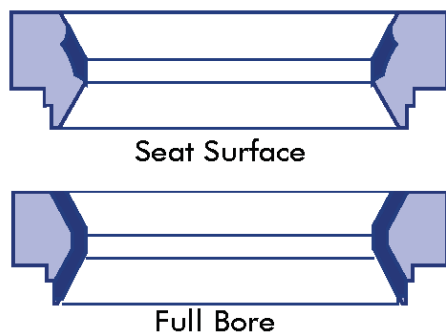

Figure 17: Hard Facing Variations - Seat Cv Data

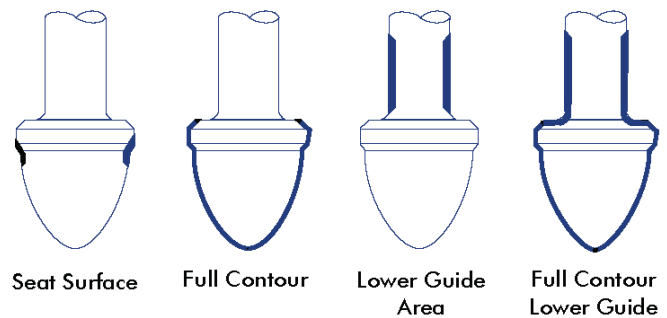

Figure 18: Hard Facing Variations-Plug





# GFlo

## Materials of construction

**Table 10: Body Materials**

Sizes	1A> - 60 inch; class 150 thru 600 1 / 2 - 18 inch; class 900 thru 1500 1 / 2 - 12 inch; class 2500 DN 10 ~ DN 1500
Forms	Globe, angle, 3-way
ANSI Ratings	Class 150, 300, 600, 900, 1500, 2500
JIS Ratings	10K, 16K, 20K,30K, 40K, 63K
DIN Ratings	PN 6, 10, 16, 25, 40,64, 100, 160,250
Materials	Carbon steel , Stainless Steel, Monel, Nickel, Chrome-Moly , Titanium, Alloy 20, Bronze, Hastelloy B, Hastelloy C, other castable materials
End Connections	Separable flange: 1 / 2 - 4 inch, class 150 thru 600 6-8 inch, class 300 and 600 Integral flange: all sizes NPT: 1 / 2 - 4 inch Socket Weld: 1 / 2 - 4 inch Graylag: all sizes
Separable End Flange Material	Carbon steel, 316 stainless steel; other material as required

**Table 11: Bonnet Materials**

Types	Standard, standard extension, special length extension, bellows seal, cryogenic
Flange	Separable
Materials	Bonnet: same as body Bellows: Stainless steel, other materials as required Bellows Housing: carbon steel, 316 stainless steel, other materials as required Bonnet flange: carbon steel, 316 stainless steel, other material as required

**Name plate**

Valves are equipped with stainless steel name plates. An example is illustrated below.

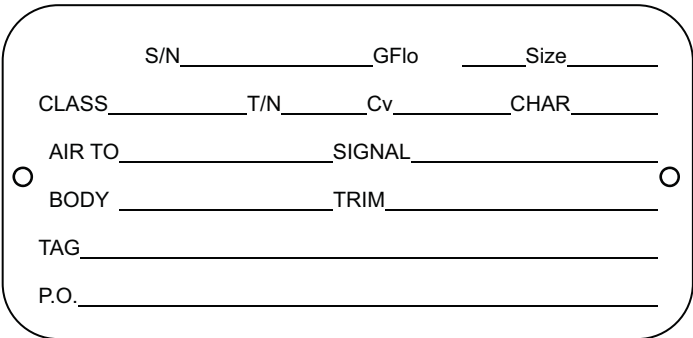



# GFlo

## Materials of construction

**Table 12: Packing**

Configurations	Standard, Twin seal, Vacuum seal
Materials	Teflon V-ring, Teflon AFP*, AFP/Inconel wire, Glass-filled Teflon V-ring, Braided Teflon, Grafoil, other materials as required
Lubrication (optional)	Lubricator w/integral isolation valve Lubricator w/additional isolation valve

**Table 13: Trim**

Characteristics	Equal percentage, Linear, Quick opening	
Materials	316 stainless steel	Alloy 20
	304 stainless steel	Nickel
	347 stainless steel	Titanium
	416 stainless steel	Monel
	Hastelloy B	17-4 PH
	Hastelloy	440 C
Hard Facings	Materials: #6 Stellite, #5 Colmonoy Types: seat surface, full contour, full bore, lower stem guide area	
Soft Seat	TFE Teflon, FEP Teflon, KEL-F, Polyurethane, PEEK	
Pressure-balanced	Sizes: 2-inch and larger, Seal types: elastomer, metal	

**Table 14: Guides**

Type	Double-top stem
Materials	Glass-filled Teflon, Grafoil, Stellite, bronze, other materials as required

**Table 15: Gaskets**

Types	Spiral wound: 304 or 316 stainless steel/non-asbestos filler, Teflon, Grafoil, Flat: Teflon, soft metal Metal O-ring: Inconel X750/silver plated
-------	--

**Table 16: Actuators**

Types	Double acting cylinder with positive fail-safe spring action, Manual handwheel Electro-hydraulic Electro-mechanical
Sizes	Cylinder: 25, 50, 100 square inch (standard); 200, 300, 400, 500, 600 square inch (optional) Manual Handwheel: 9, 12, 18, 24-inch diameter
Auxiliary	Side-mounted: continuously-connected Top-mounted: continuously-connected, push-only, limit stops
Materials	Cylinder: anodized aluminum Piston: anodized aluminum Actuator stem: 416 stainless steel Yoke: ductile iron O-rings: Buna N
Action	Air-to-open, Air-to-close (field reversible)
Max. Working Pressure	150 psig / 10.3 Barg

**Table 17: Positioner**

Types	Pneumatic, Electro-pneumatic
Input Signals	Pneumatic: 3-15, 3-9, 9-15, 6-30 psig 0-1, 0-0.6, 0.6-1, 0.4-2.1 Barg and split ranges Electro-pneumatic: 4-20, 10-50 mA
Supply Pressure	40-150 psig / 2.8-10.3 Barg (no supply regulator required)
Standard Materials	Aluminum, stainless steel, Buna N, nickel-plated brass
Adjustments	Stroke range, zero, balance pressure
Action	Air-to-open, Air-to-close (field reversible)

\*Asbestos Free Packing (AFP)



## Estimated shipping weights

**Table 18: Estimated Shipping Weights**  
GFlo, Flanged Valves with Cylinder Actuators and Positioners

Weight in Lbs. / Kgs.							
Size (inches)	Class 150	Class 300	Class 600	Class 900	Class 1500	Class 2500	Add for Extended Bonnet
1/2 - 3/4	40/18	40/18	40/18				5/2
1	50/23	50/23	50/23	100/45	120/54	150/68	5/2
1 1/2	65/30	65/30	65/30	170/54	180/82	210/95	5/2
2	75/34	75/34	75/34	200/91	220/100	300/136	5/2
3	160/73	170/77	180/82	400/182	430/195	500/227	15/7
4	240/109	250/114	265/120	590/268	610/277	940/427	20/9
6	360/163	570/259	600/272	1000/454	1170/531	1400/636	40/18
8	590/268	790/359	830/377	1100/499	1320/599	1740/790	65/30
10	1050/477	1405/638	1600/726	2050/931	2200/999	2600/1180	90/41

**Table 19: Oversize Actuator Weights (lbs / kg)**

**Part Identification**

Nearly every part on a MVA valve has an identification number, along with material code number.

Original Size	Over Size	Add
25	50	30/14
50	100	90/41
100	200	125/57

For higher/other sizes, please contact factory



# GFlo

## Overall dimensions

**Table 20: GFlo Body Dimensions - Class 150, 300, 600 (in. / mm)**

Body Size (inches)	A								B		H				Clearance Above Actuator Required for Disassembly	
	ANSI/Globe*		ANSI/ISA**								Standard Bonnet		Extended Bonnet			
	Class 150, 300, 600		Class 150		Class 300		Class 600									
1/2 & 3/4	8.5	216	7.3	184	7.6	194	8.1	206	1.5	38	3.8	97	8.3	212	2.5	64
1	8.5	216	7.3	184	7.8	197	8.3	210	1.8	44	3.8	97	8.3	212	2.5	64
1 1/2	9.5	241	8.8	222	9.3	235	9.9	251	2.3	59	5.2	132	9.7	246	4.0	102
2	11.5	292	10.0	254	10.5	267	11.3	286	2.3	57	5.4	138	9.9	252	4.5	114
3	14.0	356	11.8	298	12.5	318	13.3	337	3.4	86	6.8	172	12.3	312	5.8	147
4	17.0	432	13.9	353	14.5	368	15.5	394	5.2	133	8.4	214	13.9	354	7.5	190
6			17.8	451					5.5	139	10.1	256	15.6	395	10.0	254
6					18.6	473	20.0	508	5.8	146	12.3	311	17.8	451	10.0	254
8			21.4	543					7.1	180	12.5	318	18.0	457	10.9	277
8					22.4	568	24.0	610	7.5	190	14.4	365	19.9	505	11.4	290
10			26.5	673					8.4	214	14.1	359	19.6	498	11.9	302
10					27.9	708	29.6	752	8.9	227	14.1	359	20.6	524	12.1	308
12			29.0	737					9.6	243	14.1	359	19.6	498	12.6	320
12					30.5	775	32.3	819			16.3	413	22.8	578	12.6	320

\* MVA standard per ANSI/ISA s75.20, 1992 \*\*Per ANSI/ISA S75.03, 1985 For screwed end use 8.3 / 210

**For higher/other sizes, please contact factory**

**Table 21: GFlo Body Dimensions - Class 900, 1500, 2500 (in. / mm)**

Body Size (in.)	A				B				H				Clearance Required for Disassembly							
	Face-to-Face *				Class 1500, 2500				Standard Bonnet		Extended Bonnet		Class 900, 1500, 2500		Class 900, 1500, 2500					
	Class 900, 1500		Class 2500						Class 900, 1500	Class 2500	Class 900, 1500	Class 2500								
1	11.0	279	12.0 <sup>2</sup>	305 <sup>2</sup>	1.8	44	1.8	44	5.6	143	6.8	173	10.1	257	11.3	286	3.6	90	3.6	90
1 1/2	13.0	330	15.0 <sup>1</sup>	381 <sup>1</sup>	2.7	68	2.4	60	8.7	220	8.7	221	13.2	334	13.2	334	5.6	141	5.6	141
2	14.8	375	15.8	400	2.8	71	3.0	77	8.7	220	8.7	221	13.2	334	13.2	334	6.1	154	6.1	154
3	18.1	460	26.0 <sup>1</sup>	660 <sup>1</sup>	4.2	106	3.7	94	11.4	289	12.9	328	18.4	467	19.9	506	8.4	214	8.3	211
4	20.9	530	29.0 <sup>1</sup>	737 <sup>1</sup>	4.4	113	5.4	138	12.4	316	14.6	371	19.4	496	21.6	549	9.7	246	10.7	272
6	30.0 <sup>2</sup>	762 <sup>2</sup>	34.0 <sup>1</sup>	864 <sup>1</sup>	7.2	183	7.3	184	16.4	416	17.4	442	23.4	594	27.3	692	12.2	309	13.6	344
8	32.8	832	40.3	1022	9.4	240	10.3	262	18.6	473	24.3	616	24.2	613	31.3	794	16.7	424	17.8	451
10	39.0	991	50.0	1270	11.2	284	10.0	254	21.9	556	26.0	660	28.9	734	33.0	838	18.3	465	19.5	495
12	44.5	1130	56.0	1422	14.0	356	12.9	327	26.6	675	28.0	711	33.6	852	35.0	889	19.4	492	20.5	521
14	49.5	1257							24.8	629			31.8	806			20.5	521		

\* ANSI/ISA S75.15, 1987; (1) Per ANSI/ISA S75.16, 1987; (2) MVA standard

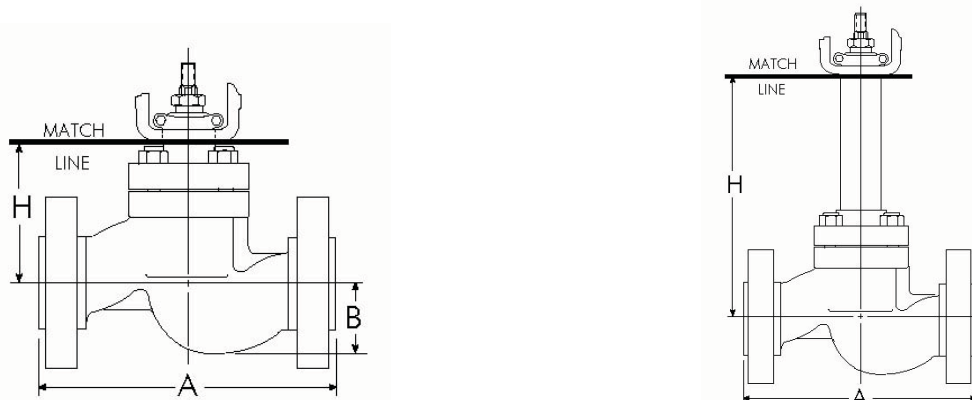



# GF10

## Overall dimensions

**Table 22: Cold Box Extended Bonnet (in. / mm)**

Body Size (inches)	Body Rating Class	H					
		Std. Cold Box Ext.					
½ to 1	150 to 600	15.0	381	24.0	610	27.0	686
1 ½	150 to 600	15.0	381	24.0	610	27.0	686
2	150 to 600	15.3	387	24.3	616	27.3	692
3	150 to 600	18.0	457	24.0	610	27.0	686
4	150 to 600	18.0	457	24.0	610	27.0	686
6	150	18.0	457	24.0	610	27.0	686

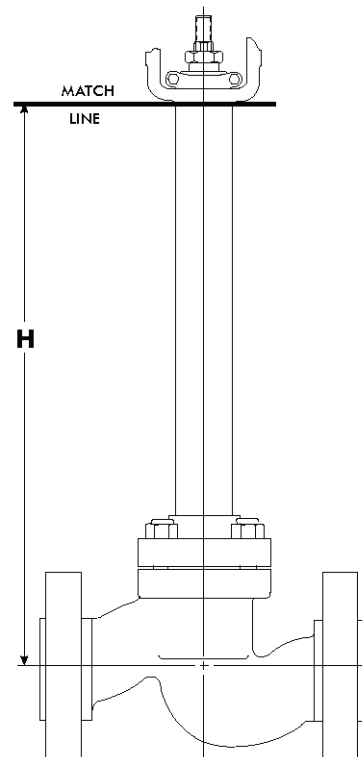

**Table 23: Angle Body (in. / mm)**

Body Size (inches)	Body Rating Class	A		H				Clearance Required for Disassembly	
				Standard Bonnet		Extended Bonnet			
½ to 1	150 to 600	4.3	108	3.1	78	7.6	192	2.5	64
1 ½	150 to 600	4.8	121	3.6	92	8.1	206	4.0	102
2	150 to 600	5.8	146	3.9	100	8.4	214	4.5	114
3	150 to 600	7.0	178	4.9	124	10.4	264	5.8	147
4	150 to 600	8.8	222	6.2	156	11.7	295	7.5	190
6	150	8.9	226	7.1	180	12.6	320	10.0	254
	300 to 600	11.0	279	9.5	241	15.0	381	10.0	254
8	150, 13.0, 330	13.0	330	9.0	229	14.5	368	13.8	349
	300 to 600	13.0	330	10.8	275	16.3	414	13.8	349

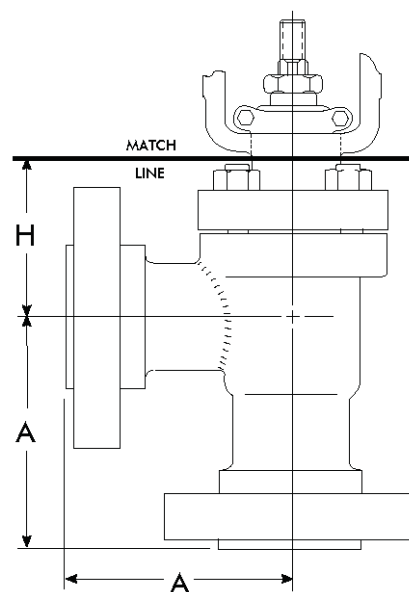

½ to 1	900, 1500 2500	5.5	140	4.7	119	9.2	234	3.6	90
		6.0	152	5.8	147	10.3	262	3.6	90
1 ½	900, 1500 2500	6.5	165	6.5	165	11.0	279	5.6	142
		7.5	191	7.0	178	11.5	292	5.6	142
2	900, 1500 2500	7.3	185	7.1	180	11.6	295	6.1	155
		8.9	226	7.9	201	12.4	315	6.1	155
3	900, 1500 2500	9.3	236	9.8	249	16.8	427	8.4	213
		13.0	330	11.2	284	18.2	462	8.3	211
4	900, 1500 2500	12.5	318	11.1	282	18.1	460	9.7	246
		14.5	368	12.6	320	19.6	498	10.7	272
6	900, 1500 2500	13.9	353	13.3	338	20.3	516	12.2	310
		17.0	432	16.1	409	23.1	537	13.6	345
8	900, 1500 2500	16.4	417	14.5	368	21.5	547	16.7	424
		20.1	511	20.8	528	27.8	706	17.8	452
10	900, 1500 2500	19.5	495	15.6	396	22.6	574	18.3	465
		25.0	635	21.1	536	28.1	714	16.3	414





# GF10

## Body sub-assembly

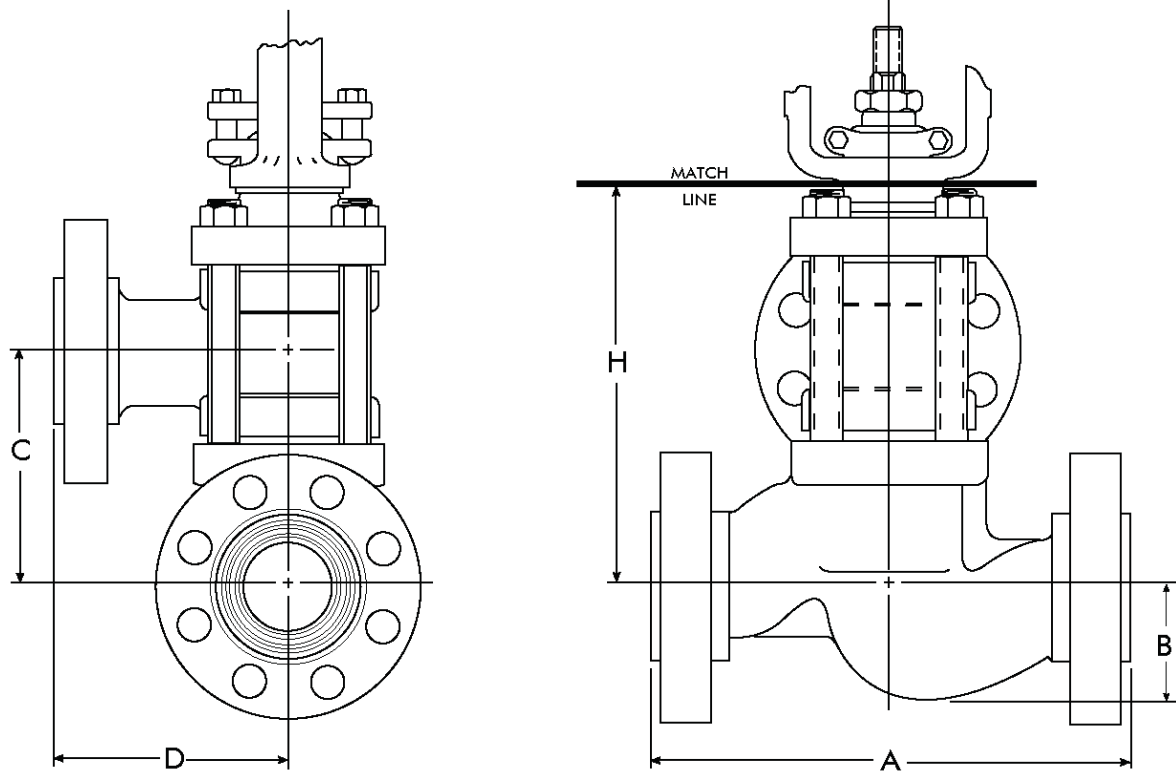

**Table 24: Three-way Body (in. / mm)**

Body Size (in.)	ANSI/ Globe Class 150,300,600		A						B		C		D		H			Clearance Required for Disassembly		
			ANSI/ISA												Std. Bonnet		Extd. Bonnet			
	Class 2500	Class 1500	Class 2500	Class 2500	Class 1500	Class 2500	Class 2500	Class 2500	Class 2500	Class 2500	Class 2500	Class 2500	Class 2500	Class 2500	Class 2500	Class 2500	Class 2500			Class 2500
1/2 - 3/4	8.5	216	7.3	184	7.6	194	8.1†	206†	1.5	38	3.4	87	4.3	108	6.7	170	11.2	284	3.4	86
1	8.5	216	7.3	184	7.8	197	8.3	210	1.8	44	3.4	87	4.3	108	6.7	170	11.2	284	3.4	86
1 1/2	9.5	241	8.8	222	9.3	235	9.9	251	2.3	59	5.4	137	4.8	121	9.1	230	13.4	341	5.0	127
2	11.5	292	10.0	254	10.5	267	11.3	286	2.3	59	5.6	143	5.8	146	9.3	236	13.7	347	5.5	140
3	14.0	356	11.8	298	12.5	318	13.3	337	3.4	86	7.6	194	7.0	178	13.0	329	18.5	470	7.1	181
4	17.0	432	13.9	353	14.5	368	15.5	394	5.2	133	9.9	251	8.5	216	16.7	423	22.1	562	9.4	240
6			17.8	451					5.5	139	14.0	356	8.9	226	21.6	548	26.6	675	11.6	294
6					18.6	473	20.0	508	5.8	146	16.0	406	10.0	254	25.8	654	31.3	794	11.6	294
8			21.4	543					7.0	179	15.0	381	10.7	272	23.9	608	29.4	748	12.2	310
8					22.4	568	24.0	610	7.5	191	18.3	464	12.0	305	30.2	767	35.7	907	12.2	310

\* Per ANSI B16.10, 1986 \*\*

Per ANSI/ISA S75.03, 1985

† For screwed end use 8.3/210

# GFlo

## Severe Service Trims (Cavitation Control)



Cavitation damage to valve components is effectively minimized by controlling the location of vapor bubble implosion in an area away from metal parts in the MVA CavFlo trim.

### Cavitation Damage - A Problem :

Whenever the pressure of flowing liquid through a restricted area of a control valve drops below the vapor pressure of the liquid and recovers to a pressure above the vapor pressure, cavitation damage to control valve and piping components may occur. In the first stage of cavitation, vapor bubbles form downstream of the restricted area at the vena contracta (point of narrowest fluid constraint).

The enlarging passage at downstream of the vena contracta reduces the velocity and thereby associated pressure recovery causes the vapor bubbles collapse or implode suddenly.

This implosion of the bubbles on metal surfaces causes stresses eventually resulting in tearing away particles of the metal from the surface towards inward. Cavitations damages plug and seat of a control valve as throttling occurs at the restriction in the clearance between the plug and seat ring. If the vapor bubbles implode near them, the valve body and piping can also be damaged.

Conventionally harder material is used to minimize

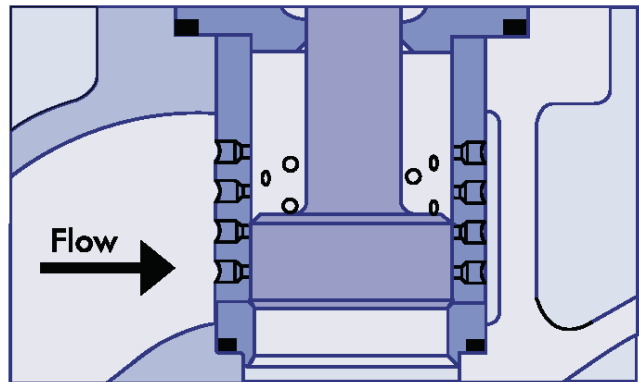

### Cavitations Control Trim -A Solution :

MVA 's CavFlo Trim utilizes many small holes for diametrical flow through the walls of the seat retainer. As the valve plug lifts, increased pairs of holes are opened. Each hole discharges a jet of cavitating liquid at the center of retainer, which impinges with a jet of liquid admitted through the opposing hole.

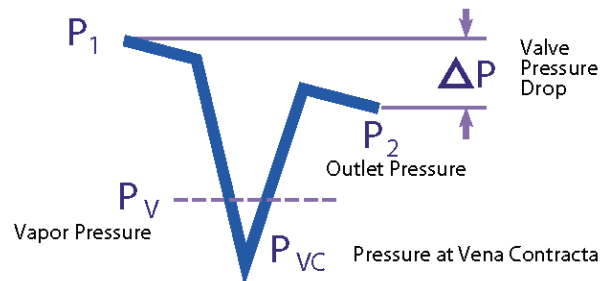

Pressure Profile: Single Seat Valve Experiencing Cavitation



# GFlo

## Severe Service Trims (**Cavitation Control**)

The impinging fluid jets form an area of pressure recovery and a fluid cushion. This phenomenon collapses the vapor bubbles in the fluid stream, away from metal parts preventing damages. Stepped holes are used to ensure solid flow and not the hollow tube like flow through the retainer. Thus vena contracta established outside the retainer and not in the retainer. The turbulence of the flow inside the retainer promotes collapsing of the vapor bubbles in the middle of seat retainer, reducing damage to valve trim. CavFlo Trim fits standard GFlo series valve bodies, with pressure-balanced and unbalanced options being available. Because the valve plug slides in the retainer closely, regulating the fluid flow through the holes, the fluid must be free from dirt and pipe muck to avoid seizing of plug with retainer. Size and spacing of holes in the retainer determine flow characteristics and capacity. To achieve desired flow characteristic different sizes of holes with variable spacing can be used on the same size of retainer. CavFlo Trim will always use flow direction of valves as over the plug.

### Standard Materials of Construction

Seat Retainer	316 stainless steel or 416 hardened stainless steel
Plug	316 stainless steel with Stellite facing
Seat Ring	316 stainless steel with Stellite facing

**NOTE:** Refer to MVA's Globe Valve Body Assembly Bulletin for additional specifications. C C can reduce cavitation damage in low pressure services.



# GFlo

## Severe Service Trims (Noise Reduction)

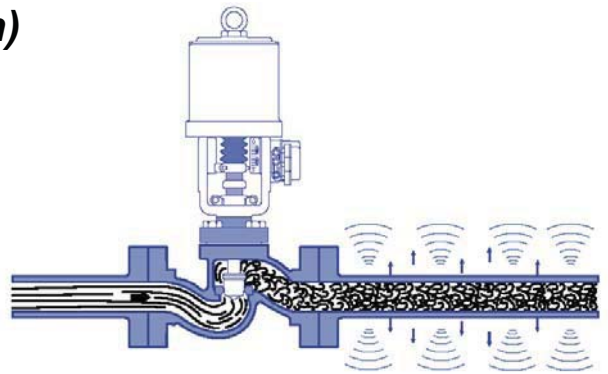

MagaFlo trim overcome the problem of control valve noise by dealing effectively with gaseous pressure reduction, and by controlling turbulence carried into the downstream piping. The Basic Principles In conventional single-throttling-point globe control valves, a vena contracta (point of greatest flow constriction) occurs immediately at the downstream of throttling point. A simplified pressure profile of the fluid as it passes through the valve shows slight pressure loss in the inlet and outlet passages, and a substantial reduction of pressure at the vena contracta. Note that the overall pressure drop between the inlet and the outlet does not reveal how far the pressure may have dropped within the valve itself.

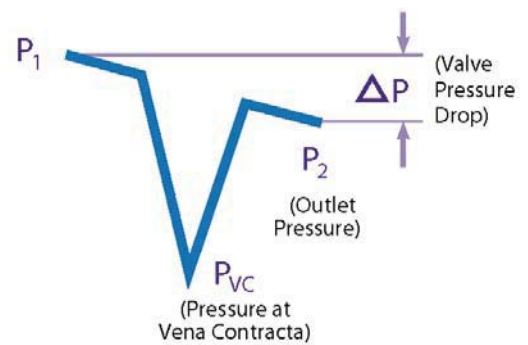

Pressure Profile Single Seat

The Problem with Gases The problem becomes apparent by superimposing a velocity profile on the pressure profile, discussed above. For single-throttling-point control valves, with the sharp pressure reduction, the velocity will be greatly increased at the vena contracta. While considerable noise can be generated as velocities in the valve approach sonic levels, substantial noise can be generated even where inlet and outlet velocities are significantly less than sonic.

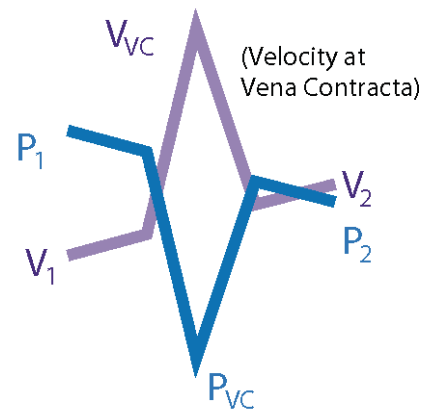

Gaseous Noise

The Solution Without allowing a sharp pressure drop at the vena contra reduce the pressure from inlet to outlet gradually. Thus, gaseous velocities are maintained at remarkable values throughout the valve and high noise levels are simply not generated. Also, by breaking the flow into many small flow Streams, turbulent energy is reduced and dissipated. In addition, noise generated upstream is substantially blocked by successive stages.

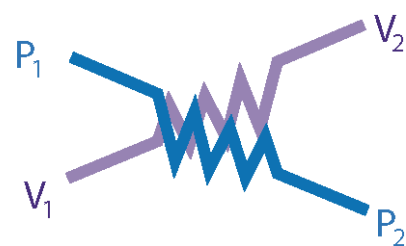

The Solution

**Down stream noise reduction (dB) plates are also available**



# Electrical Actuator

## *Electrically Actuated Valves*

### **ELECTRICAL LINEAR ACTUATORS FOR :**

Globe ( 2 way & 3way ) Valves  
Sluice Gate Valves  
Weirflo Diaphragm Valves  
Knife edge Gate Valves  
Flush Bottom Discharge Valves

### **ACTUATOR SPECIFICATIONS :**

Type Electric, Reversible, Linear Movement  
Housing Aluminum Alloys  
Power supply 230 V Single Phase 50 HZ / 415 V  
three phase  
Duty On-Off with direct power supply  
throttling with input signal of 4-20 MA  
Enclosure Weather Proof I/P-65 flame proof  
confirming to group IIA, IIB & IIC

### **TEMPERATURE :**

Class T6  
Gear Box With Metallic Heat Treated Gears

### **STANDARD ACCESSORIES :**

Travel Limit Switches ( 1 NO + 1 NC ) - 2 Nos Torque  
Switches

### **LOCAL POSITION INDICATOR :**

Optional Accessories :

Hand Wheel

Auxiliary limit switches (1 NO + 1 NC) - 2 Nos

### **FEED BACK POTENTIOMETER :**

Input Linear Mechanical movement  
Output 100 to 235 OHMS

### **TWO WIRE POSITION TRANSMITTER :**

Input 100 to 235 OHMS  
Output 4 to 20 mA  
Panel Box With Open/ Close/ Stop Push Buttons

### **ELECTRICAL ROTARY ACTUATORS FOR :**

Shut off Ball Valves  
Throttling V-Ball Valves  
Butterfly Valves  
Rotary Plug Valves  
Dampers

### **ACTUATOR SPECIFICATIONS :**

Type Electric, Reversible, 0 to 90° Rotation  
Housing Aluminum Alloys  
Power Supply 230 V Single Phase 50 HZ / 415 V  
Three Phase  
Duty On-Off with direct power supply  
throttling with input signal of 4-20 MA  
Enclosure Weather Proof I/P-65 flame proof  
confirming to group IIA, IIB & IIC

### **TEMPERATURE :**

Class T6  
Gear Box With Metallic Heat Treated Gears

### **STANDARD ACCESSORIES :**

Travel limit Switches ( 1 NO + 1 NC ) - 2 Nos Torque  
Switches

### **LOCAL POSITION INDICATOR**

Optional Accessories :

Hand Wheel

Auxiliary Limit Switches (1 NO + 1 NC) - 2 Nos

### **FEED BACK POTENTIOMETER**

Input Mechanical Movement  
Output 100 to 235 OHMS

### **TWO WIRE POSITION TRANSMITTER**

Input 100 to 235 OHMS  
Output 4 to 20mA  
Panel Box With Open/ Close/ Stop Push Buttons

## **MVA Corporation**

No.120-1, Niaosong 3rd St., Yongkang Dist., Tainan City 710, Taiwan (R.O.C.)

Tel. +886-6-242-3111 | Fax.+886-6-242-5699

E-mail: frank.chen@mvac.com.tw | Website: www.mvac.com.tw